

# NAVAL JUNIOR RESERVE OFFICERS TRAINING CORPS

## NJROTC



# SUPPLY MANUAL

## NAVEDTRA 37123-B

Aug 2009

# TABLE OF CONTENTS

	<u>PAGE</u>
<b>CHAPTER 1: GENERAL INFORMATION .....</b>	<b>1</b>
RESOURCES.....	1
<i>Table 1-1. Appropriation Types .....</i>	<i>1</i>
UNIT SUPPORT AND MAINTENANCE .....	2
REQUISITIONING PROCEDURES.....	2
<i>Table 1-2. Requisition Guide .....</i>	<i>3</i>
REQUISITION NUMBERS .....	4
REQUISITION FOLLOW-UP AND DISCREPANCY PROCEDURES.....	5
<i>Table 1-3. Julian Date Calendar (Perpetual).....</i>	<i>6</i>
<i>Table 1-4. Julian Date Calendar for Leap Years.....</i>	<i>7</i>
<b>CHAPTER 2: UNIFORMS AND ORGANIZATIONAL ITEMS.....</b>	<b>9</b>
ALLOWANCE.....	9
REQUISITIONING .....	9
RIBBONS.....	9
<i>Table 2-1. NJROTC Cadet Male Uniform Requirements .....</i>	<i>10</i>
<i>Table 2-2. NJROTC Cadet Female Uniform Requirements.....</i>	<i>11</i>
<i>Table 2-3. NJROTC Ribbons.....</i>	<i>12</i>
<i>Table 2-4. NJROTC Ribbon Devices.....</i>	<i>13</i>
CLOTHING SIZES .....	13
<i>Table 2-5. Women’s Measurement Locations .....</i>	<i>13</i>
ISSUE CONTROL .....	13
<i>Table 2-6. Women’s Body Measurement Chart .....</i>	<i>14</i>
<i>Figure 2-1. Custody Card .....</i>	<i>15</i>
RETURN OF UNIFORMS.....	16
ALTERATIONS TO UNIFORMS.....	16
ORGANIZATIONAL ITEMS .....	16
<i>Table 2-7. Organizational Items .....</i>	<i>16</i>
UNIT FLAG DESIGN.....	17
<i>Figure2-2. NJROTC Unit Flag Design.....</i>	<i>17</i>
<b>CHAPTER 3: PUBLICATIONS AND INSTRUCTIONAL MATERIAL .....</b>	<b>19</b>
GENERAL INFORMATION .....	19
NJROTC REGULATIONS.....	19
NJROTC TEXTBOOKS/EQUIPMENT .....	19
NOTETAKING SHEETS .....	20
<i>Figure 3-1. Sample JUMS NJROTC Textbook/Equipment Receipt (in JUMS).....</i>	<i>20</i>
<i>Table 3-1. Instructional Material Allowances .....</i>	<i>21</i>
<i>*Reference books are not replaced yearly and units ordering these items may not receive the most current editions. New editions are not issued until stock of older edition has been depleted. ....</i>	<i>21</i>
<i>Table 3-2. Instructional Material Detailed Listing.....</i>	<i>22</i>
<i>*Reference books are not replaced yearly and units ordering these items may not receive the most current editions. New editions are not issued until stock of older edition has been depleted. ....</i>	<i>23</i>
<b>CHAPTER 4: FORMS.....</b>	<b>25</b>
FORMS LIST .....	25
<i>Table 4-1. Generally Required Forms .....</i>	<i>25</i>

	<u>PAGE</u>
<b>CHAPTER 5: VIDEO TRAINING AIDS.....</b>	<b>26</b>
ALLOWANCE.....	26
<i>Table 5-1. Videotapes/CDs .....</i>	<i>26</i>
<b>CHAPTER 6 : AUDIOVISUAL/INFORMATION TECHNOLOGY EQUIPMENT.....</b>	<b>29</b>
ALLOWANCES .....	29
<i>Table 6-1. Audiovisual Equipment Allowance .....</i>	<i>29</i>
<i>Table 6-2. Information Technology Equipment Allowance .....</i>	<i>29</i>
<b>CHAPTER 7: DRILL RIFLES.....</b>	<b>31</b>
ALLOWANCE.....	31
<i>Table 7-1. Authorized Dummy Drill Rifles.....</i>	<i>31</i>
ALLOWANCE CHANGES .....	31
INVENTORY .....	32
SURVEY OF DRILL RIFLES .....	32
RETURN OF DRILL RIFLES .....	32
DISPOSITION INSTRUCTIONS.....	32
TRANSFER OF DRILL RIFLES BETWEEN UNITS .....	33
SECURITY .....	33
REPAIR.....	33
<i>Figure 7-1. Repair Parts for MK5-0 and MK5-1 Drill Rifles .....</i>	<i>34</i>
<i>Figure 7-2. Repair Parts for MK6-0 Drill Rifle.....</i>	<i>35</i>
<i>Figure 7-3. Repair Parts for Daisy Drill Rifle 1903.....</i>	<i>37</i>
<i>Figure 7-4. Wall Style Drill Rifle Storage Rack.....</i>	<i>39</i>
<i>Figure 7-5. Free Standing Drill Rifle Storage Rack .....</i>	<i>42</i>
<b>CHAPTER 8: AIR RIFLES .....</b>	<b>45</b>
CLASSES .....	45
TYPES.....	45
AUTHORIZATION .....	45
ORDERING .....	45
AMMUNITION .....	45
REPAIR.....	45
INVENTORY.....	46
SECURITY .....	46
<i>Figure 8-1. Repair Parts for Daisy 853 .....</i>	<i>47</i>
<b>CHAPTER 9: PROPERTY MANAGEMENT.....</b>	<b>49</b>
INVENTORY CONTROL.....	49
MILITARY PROPERTY CUSTODIAN (MPC) .....	49
NJROTC MILITARY PROPERTY .....	49
ANNUAL INVENTORY .....	50
RELIEF FROM RESPONSIBILITY .....	50
CUSTODY TRANSFER.....	51
EXCESS PERSONAL PROPERTY .....	51
SURVEY .....	51
MISSING, LOST, STOLEN, OR RECOVERED GOVERNMENT PROPERTY .....	51

	<u>PAGE</u>
<b>CHAPTER 10: DONATIONS OF SURPLUS PERSONAL PROPERTY .....</b>	<b>53</b>
GENERAL INFORMATION .....	53
SCREENING CATEGORY .....	53
SCREENING LETTER.....	53
<i>Figure 10-1. Screening Letter</i> .....	53
ITEMS DONATABLE TO NJROTC UNITS .....	54
APPLICATION FOR DONATION OF SURPLUS PROPERTY.....	54
<b>CHAPTER 11: PROCEDURES FOR DISESTABLISHMENT.....</b>	<b>55</b>
GENERAL .....	55
ACCOUNTABILITY .....	55
DISPOSITION GUIDANCE PLAN .....	55
DISPOSITION OF MATERIALS .....	55
DISPOSITION OF FUNDS COLLECTED .....	55
DISPOSITION OF ADMINISTRATIVE MATERIAL .....	56
PACKING AND SHIPPING MATERIALS .....	56

## CHAPTER 1: GENERAL INFORMATION

The Navy Junior Reserve Officers Training Corps (NJROTC) program is composed of NJROTC units established in secondary level educational institutions of the United States under authority of Title 10, U.S. Code, Chapter 102. NJROTC units are provided with the administrative and logistic support necessary to operate effectively through directives and instructions from the Commander, Naval Service Training Command (NSTC) via the NJROTC Area Managers.

Each unit’s Senior Naval Science Instructor (SNSI) is responsible for all aspects of material management. Within the unit, material management functions include monitoring and receipt control of procurements, uniform and textbook issue control, and miscellaneous functions as assigned to effectively operate the unit.

### RESOURCES

NJROTC cadets are provided with uniforms, books, training aids, and other types of equipment, which are paid for by the Navy. The NJROTC program receives monies primarily from two different Congressional appropriations: O&MN and [MPN](#).

The O&MN appropriation provides resources for the daily operation and maintenance of the Navy. In support of NJROTC, it funds books, fees, communications (e.g. telephone), consumable supplies, travel, equipment costing less than \$50,000, and other organizational material such as pennants, flags, etc. In addition, NJROTC host schools are provided with unit support and maintenance funds every fiscal year to support various routine NJROTC expenses. The MPN appropriation provides for basic uniform items in support of the NJROTC program.

*Table 1-1. Appropriation Types*

<b>APPROPRIATION TYPE</b>	<b>TYPE OF EXPENDITURES</b>	<b>EXAMPLES</b>	<b>PROCEDURES</b>
<a href="#">MPN</a>	Uniform items	See tables 2-1, 2-2	Order via JUMS
	Uniform maintenance	Tailoring, dry-cleaning	Procure locally and submit claim to accounting
<b>O&amp;MN</b>	Organizational items	See table 2-7	Order via JUMS
	Cadet travel	Orientation trips	Submit claim to accounting
	Navy-owned equipment and material	A/V, computers, textbooks and other instructional material	Purchased by NSTC and shipped to units
	Unit support and maintenance	See listing below	NSTC provides unit with <a href="#">EFT</a> or check

## **UNIT SUPPORT AND MAINTENANCE**

The following expenses are common examples of items that should be funded from the unit support and maintenance funds provided to the school for support of the NJROTC program:

- Minor repairs to computer & classroom equipment
- FED EX charges to send equipment to Saufley Field for repairs
- Long distance toll charges and message units
- Audiovisual equipment repairs and supplies
- Subscriptions to Navy-related publications and periodicals
- Nametags
- Printing and engraving
- Plaques, trophies, ribbons, frames, and folders
- Entrance fees
- Air rifle and drill team equipment and supplies
- Air rifle range fees
- Flags and related parade equipment
- Film, developing costs, and other camera supplies
- Digital camera
- Advertising and publicity materials
- Subscription to Navy Times
- Keys and locks
- Software
- Postage
- Internet access

If an expense is not included on this list, contact the Area Manager **before** incurring the expense.

## **REQUISITIONING PROCEDURES**

The NJROTC unit will use the requisitioning procedures shown in table 1-2 for requirements that are not routine direct expenses. Any item not covered in the table or included in routine expenses should be requested from the Area Manager.

**Table 1-2. Requisition Guide**

ITEM		ALLOWANCE	FUNDING	STANDARD PROCEDURES
<b>AIR RIFLES (Chapter 8)</b>	Initial issue	10	NSTC	Authorization letter to unit/school Purchase order Reimbursement via SF1034
	Maintenance/ Repair	As required	Unit support funds	School purchase order/check to vendor
<b>AUDIO- VISUAL EQUIPMENT (Chapter 6)</b>	Initial issue	See table 6-1	NSTC	NSTC procure and ship to unit
	Replacement (normal wear and tear)	As required	NSTC	JUMS DD200 survey via Area Mgr NSTC procure and ship to unit
	Replacement (stolen)	As required	School insurance	JUMS DD200 survey with school check via Area Mgr NSTC procure and ship to unit
	Maintenance/ Repair	As required	Unit support funds	School purchase order/check to vendor
<b>DRILL RIFLES (Chapter 7)</b>	Initial issue	30	NSTC	NSTC procures for direct shipment to unit or NSTC ships rifles from disestablished unit
	Support (spare parts)	As required	NSTC	<a href="#">Unit requisitions from NSTC via email</a>
	Allowance changes	As authorized	NSTC	Unit letter with justification to NSTC via Area Mgr
<b>FORMS (Chapter 4)</b>		As required	NSTC	Available via Area Manager
<b>PUBLICATIONS (Chapter 3)</b>	Initial issue	Based on Enrollment	NSTC	NSTC procures for direct shipment to unit
	Replacement	Based on Enrollment	NSTC	Order submitted annually via JUMS AIMR
	Allowance changes	As authorized	NSTC	Email with justification to NSTC with Area Manager approval
<b>SURPLUS PROPERTY (Chapter 10)</b>		As authorized By Area Manager	None	Varies by state
<b>VIDEO TRAINING AIDS (Chapter 5)</b>	Initial issue	1 per unit	NSTC	NSTC procures for direct shipment to unit
	Replacement	As required	NSTC	Email to NSTC with Area Manager approval

Table 1-2. Requisition Guide (Cont'd)

ITEM		ALLOWANCE	FUNDING	STANDARD PROCEDURES
<b>UNIFORMS AND ORGANIZATIONAL EQUIPMENT (Chapter 2)</b>	Initial issue	As required	NSTC	NSTC procures for direct shipment to unit
	Replacement	As required	NSTC	Ordered via JUMS as authorized by Area Manager
	Swords	6 ea	NSTC	Ordered via JUMS as authorized by Area Manager

## REQUISITION NUMBERS

Most material provided from Department of Defense (DOD) activities will have a requisition number (document number) assigned to the request and the shipping documents. This number is assigned by the ordering or shipping activity. It is used to track and identify items as well as to provide status on outstanding orders.

The number is made up of the service designator, Unit Identification Code (UIC), Julian date, and a serial number. The service designator code to be used for NJROTC requisitions is “N” for Department of the Navy. The UIC is a five-digit code assigned by the Navy to identify a specific Navy activity for supply and accounting purposes. The Julian date consists of two elements: the last digit of the calendar year and the numeric consecutive day of the calendar year. Tables 1-3 and 1-4 are Julian date calendars. Ensure that the proper calendar (perpetual or leap year) is used when assigning a Julian date.

An example of a requisition number and its explanation is shown below:

N97740-6165-0001

- N Service Designator code
- 97740 Unit Identification Code (UIC) of the activity
- 6 The last digit of the calendar year (2006)
- 165 The numeric day of the calendar year (14 June)
- 0001 Serial number assigned to the requisition



## **REQUISITION FOLLOW-UP AND DISCREPANCY PROCEDURES**

Requisition follow-up discrepancy reporting for all requisitions must be completed through the Area Office via email. This procedure will ensure that a record of the request is maintained while enabling the information to be forwarded up the chain of command until resolution can be reached. NJROTC units will NOT submit a Standard Form (SF) 364, Report of Discrepancy (ROD) for any item received that appears to be damaged, is improperly packaged, or does not match the shipping documentation. If necessary, NJROTC Supply will submit the Report of Discrepancy. It is important that the unit provide as much information as possible: UIC, date of original submission, requisition number(s), nature of discrepancy, national stock number(s), and item descriptions are considered vital, and are usually readily available and easy to locate.

**NOTE: A FOLLOWUP SHOULD BE SUBMITTED FOR ANY ITEM REQUISITIONED BUT NOT RECEIVED WITHIN 30 DAYS.**

**Table 1-3. Julian Date Calendar (Perpetual)**

<b>DAY</b>	<b>JAN</b>	<b>FEB</b>	<b>MAR</b>	<b>APR</b>	<b>MAY</b>	<b>JUN</b>	<b>JUL</b>	<b>AUG</b>	<b>SEP</b>	<b>OCT</b>	<b>NOV</b>	<b>DEC</b>	<b>DAY</b>
1	001	032	060	091	121	152	182	213	244	274	305	335	1
2	002	033	061	092	122	153	183	214	245	275	306	336	2
3	003	034	062	093	123	154	184	215	246	276	307	337	3
4	004	035	063	094	124	155	185	216	247	277	308	338	4
5	005	036	064	095	125	156	186	217	248	278	309	339	5
6	006	037	065	096	126	157	187	218	249	279	310	340	6
7	007	038	066	097	127	158	188	219	250	280	311	341	7
8	008	039	067	098	128	159	189	220	251	281	312	342	8
9	009	040	068	099	129	160	190	221	252	282	313	343	9
10	010	041	069	100	130	161	191	222	253	283	314	344	10
11	011	042	070	101	131	162	192	223	254	284	315	345	11
12	012	043	071	102	132	163	193	224	255	285	316	346	12
13	013	044	072	103	133	164	194	225	256	286	317	347	13
14	014	045	073	104	134	165	195	226	257	287	318	348	14
15	015	046	074	105	135	166	196	227	258	288	319	349	15
16	016	047	075	106	136	167	197	228	259	289	320	350	16
17	017	048	076	107	137	168	198	229	260	290	321	351	17
18	018	049	077	108	138	169	199	230	261	291	322	352	18
19	019	050	078	109	139	170	200	231	262	292	323	353	19
20	020	051	079	110	140	171	201	232	263	293	324	354	20
21	021	052	080	111	141	172	202	233	264	294	325	355	21
22	022	053	081	112	142	173	203	234	265	295	326	356	22
23	023	054	082	113	143	174	204	235	266	296	327	357	23
24	024	055	083	114	144	175	205	236	267	297	328	358	24
25	025	056	084	115	145	176	206	237	268	298	329	359	25
26	026	057	085	116	146	177	207	238	269	299	330	360	26
27	027	058	086	117	147	178	208	239	270	300	331	361	27
28	028	059	087	118	148	179	209	240	271	301	332	362	28
29	029		088	119	149	180	210	241	272	302	333	363	29
30	030		089	120	150	181	211	242	273	303	334	364	30
31	031		090		151		212	243		304		365	31

**Table 1-4. Julian Date Calendar for Leap Years**

<b>DAY</b>	<b>JAN</b>	<b>FEB</b>	<b>MAR</b>	<b>APR</b>	<b>MAY</b>	<b>JUN</b>	<b>JUL</b>	<b>AUG</b>	<b>SEP</b>	<b>OCT</b>	<b>NOV</b>	<b>DEC</b>	<b>DAY</b>
1	001	032	061	092	122	153	183	214	245	275	306	336	1
2	002	033	062	093	123	154	184	215	246	276	307	337	2
3	003	034	063	094	124	155	185	216	247	277	308	338	3
4	004	035	064	095	125	156	186	217	248	278	309	339	4
5	005	036	065	096	126	157	187	218	249	279	310	340	5
6	006	037	066	097	127	158	188	219	250	280	311	341	6
7	007	038	067	098	128	159	189	220	251	281	312	342	7
8	008	039	068	099	129	160	190	221	252	282	313	343	8
9	009	040	069	100	130	161	191	222	253	283	314	344	9
10	010	041	070	101	131	162	192	223	254	284	315	345	10
11	011	042	071	102	132	163	193	224	255	285	316	346	11
12	012	043	072	103	133	164	194	225	256	286	317	347	12
13	013	044	073	104	134	165	195	226	257	287	318	348	13
14	014	045	074	105	135	166	196	227	258	288	319	349	14
15	015	046	075	106	136	167	197	228	259	289	320	350	15
16	016	047	076	107	137	168	198	229	260	290	321	351	16
17	017	048	077	108	138	169	199	230	261	291	322	352	17
18	018	049	078	109	139	170	200	231	262	292	323	353	18
19	019	050	079	110	140	171	201	232	263	293	324	354	19
20	020	051	080	111	141	172	202	233	264	294	325	355	20
21	021	052	081	112	142	173	203	234	265	295	326	356	21
22	022	053	082	113	143	174	204	235	266	296	327	357	22
23	023	054	083	114	144	175	205	236	267	297	328	358	23
24	024	055	084	115	145	176	206	237	268	298	329	359	24
25	025	056	085	116	146	177	207	238	269	299	330	360	25
26	026	057	086	117	147	178	208	239	270	300	331	361	26
27	027	058	087	118	148	179	209	240	271	301	332	362	27
28	028	059	088	119	149	180	210	241	272	302	333	363	28
29	029	060	089	120	150	181	211	242	273	303	334	364	29
30	030		090	121	151	182	212	243	274	304	335	365	30
31	031		091		152		213	244		305		366	31



## CHAPTER 2: UNIFORMS AND ORGANIZATIONAL ITEMS

The SNSI of each unit is responsible for requisitioning uniform items for cadet issue and stock replacement. The procedures in this chapter provide guidance in the acquisition of NJROTC uniforms.

### ALLOWANCE

Units are authorized a uniform allowance equal to the actual cadet enrollment (or the number pre-enrolled for the next academic year).

Medical directives prohibit the re-issue of shoes **and combination caps**. Cadets withdrawing within 30 days must return the shoes with other uniform items. If withdrawn after 30 academic days, they may retain the shoes issued.

Funding dictates that only two pairs of shoes per cadet will be issued during a 3- or 4-year academic program. If shoe replacement is required above the allowance, the cost will be borne by the cadet unless the shoes were defective or other extenuating circumstances exist. **Exceptions are at the discretion of the SNSI with Area Manager concurrence.**

### REQUISITIONING

Requisitions for uniforms, insignia, ribbons, and organizational equipment are processed using the JROTC Unit Management System (JUMS). JUMS provides an automated means for submitting NJROTC uniform clothing requisitions. It provides ordering activities with the ability to create clothing order on a Personal Computer (PC), using the JUMS Clothing Module, and copy it to a file or disk. This order can then be sent via email to the Area Manager for review and submission. Detailed guidance on the use of the JUMS is contained in the JUMS User's Manual. ***Before compiling a clothing order, ensure the most current JUMS patch has been installed by contacting the Area Office, NJROTC Supply, or by visiting the NJROTC website at [www.navyjrotc.us/portal/portal.php](http://www.navyjrotc.us/portal/portal.php). JUMS patches are now all inclusive. No separate clothing update need be installed.***

Table 2-1 shows the allowance for a male cadet; Table 2-2 shows the allowance for a female cadet. Where various sizes are available, the National Stock Numbers (NSNs) listed are the first of a series.

### RIBBONS

The NJROTC program authorizes the use of 25 ribbons. These ribbons are unique to the NJROTC program. The Naval Junior ROTC Ribbons chart shows all ribbons and devices and is provided to each NJROTC unit.

Tables 2-3 and 2-4 show the allowance of ribbons and devices and authorized unit stock levels. The sample allowance shown is standard for a typical 100-cadet unit. Actual unit allowance must be adjusted based on actual enrollment. Order numbers indicate the precedence in which the ribbons are worn, starting at the upper right and moving from right to left and top to bottom. For example, the number 4 ribbon is to the right of (or above) the number 22 ribbon.

**Table 2-1. NJROTC Cadet Male Uniform Requirements**

<b>NOMENCLATURE</b>	<b>NSN</b>	<b>QTY</b>	<b>REMARKS</b>
Belt, black w/brass tip	8445-LL-L00-0028	1	
Belt, khaki	8445-LL-L00-0027	1	
Buckle, brass	8315-LL-L00-0609	2	
Cap, garrison, khaki	8405-00-297-4023	1	
Cap, frame, combination, service	8405-00-150-2259	1	Officer/CPO only
w/crown, service hat, white	8405-00-834-8309	1	Officer/CPO only
w/strap, chin, black	8405-00-152-3952	1	CPO only
w/strap, chin, gold	8405-00-148-1016	1	Officer only
Cap, garrison, black	8405-LL-L00-7533	1	
Coat, all-weather	8405-01-220-2543	1	Optional
Coat, service dress blue	8405-00-444-1324	1	Officer/CPO only
Insignia (as required)	8455-variousNSNs		
Jacket, relaxed fit, black	8405-LL-L00-4433	1	
Leggings, white	8440-00261-4260	1	Drill team only (org item)
Necktie, black	8440-01-171-7571	1	
Overcoat (Peacoat)	8405-01-154-5780	1	Cannot be ordered without Area Manager and NSTC approval
Patch, NJROTC	8455-LL-L00-0604	5	
Shirt, khaki	8405-01-073-8495	1	
Shirt, white, short-sleeved w/epaulets	8405-LL-L00-2100	1	
Shirt, white, long-sleeved w/o epaulets	8405-00-629-8368	1	
Shirt, poly/wool, blue	8405-01-230-6173	1	
Shoes, oxford, black	8435-01-456-0156	1	
Trousers, khaki	8405-01-148-7323	1	
Trousers, working blue	8405-01-150-2054	1	Officer/CPO (2 ea)

NOTE: Where various sizes are available, the NSNs listed are the first of a series.

**Table 2-2. NJROTC Cadet Female Uniform Requirements**

<b>NOMENCLATURE</b>	<b>NSN</b>	<b>QTY</b>	<b>REMARKS</b>
Belt, black w/brass tip	8445-LL-L00-0029	1	
Belt, khaki	8445-LL-L00-0030	1	
Buckle, brass	8315-LL-L00-0610	2	
Cap, garrison, khaki	8410-01-312-7740	1	
Cap, frame, combination, service	8410-01-305-6969	1	Officer/CPO only
w/crown, service hat, white	8410-00-834-8309	1	Officer/CPO only
w/strap, chin, black	8405-00-152-3952	1	CPO only
w/strap, chin, gold	8405-00-148-1016	1	Officer only
Cap, garrison, black	8410-LL-L00-7533	1	
Coat, all-weather	8410-01-220-2511	1	Optional
Coat, service dress blue	8410-01-375-8407	1	Officer/CPO
Insignia (as required)	8455-variousNSNs		
Jacket, relaxed fit, black	8410-LL-L00-4403	1	
Leggings, white	8440-00261-4260	1	Drill team only (org item)
Necktab, black	8445-01-317-1620	1	
Overcoat (Peacoat)	8405-01-233-8819	1	Cannot be ordered without Area Manager and NSTC approval
Patch, NJROTC	8455-LL-L00-0604	5	
Shirt, khaki	8410-01-312-5154	1	
Shirt, white, short-sleeved w/epaulets	8410-01-069-6611	1	
Shirt, poly/wool, blue	8410-01-229-9436	1	
Shoes, oxford, black	8435-01-456-1571	1	
Shoes, pumps, black	8435-LL-L00-0304	1	Officer/CPO only <b>Optional</b>
Skirt, belted, poly/wool, blue	8410-01-372-1705	1	<b>Optional</b>
Slacks, khaki	8410-01-313-3770	1	
Slacks, poly/wool, blue, belted	8410-01-358-5684	1	Officer/CPO 2 ea

NOTE: Where various sizes are available, the NSNs listed are the first of a series.

**Table 2-3. NJROTC Ribbons**

<b>ORDER</b>	<b>AWARD DESIGNATION</b>	<b>ALLOWANCE</b>
1	Meritorious Achievement	Stocked and awarded by the Area Manager
2	Distinguished Unit	Stocked and awarded by the Area Manager
3	Distinguished Cadet	3 or 4
4	Honor Cadet	3 or 4
5	Cadet Achievement	Stocked and awarded by the Area Manager
6	Unit Achievement	Stocked and awarded by the Area Manager
7	Aptitude Award	10
8	Naval Science IV Outstanding Cadet	20
9	Naval Science III Outstanding Cadet	30
10	Naval Science II Outstanding Cadet	40
11	Naval Science I Outstanding Cadet	60
12	Exemplary Conduct	45
13	Academic Award	60
14	Exemplary Personal Appearance	60
15	Physical Fitness	60
16	Participation	60
17	Unit Services	10
18	Community Services	35
19	Drill Team	60
20	Color Guard	30
21	Rifle Team	30
22	Orienteering	30
23	Recruiting	10
24	Mini-Boot Camp	60
25	Sea Cruise	60



**Table 2-4. NJROTC Ribbon Devices**

DEVICE	ALLOWANCE
Lamp	5 Bronze (Naval Science - I) 5 Silver (Naval Science - II) 5 Gold (Naval Science - III) 5 Gold (Naval Science - IV)
Torch	4
Anchor	10
Star	(As needed) Bronze (2nd and 3rd subsequent award) (As needed) Silver (4th and 5th subsequent award) (As needed) Gold (6th, 7th, and 8th subsequent award)

**CLOTHING SIZES**

Clothing sizes are shown in the JUMS clothing module with the NSN, description, price, and unit of issue. Sizes listed are the only sizes available from standard stock. Special orders for outsized clothing are NOT AUTHORIZED expenditures of any Navy provided funding.

Women’s Body Measurements - **Exact measurements are crucial in order to obtain proper uniform fit.** The following table shows the correct measurement locations.

**Table 2-5. Women’s Measurement Locations**

Bust	Measure around the fullest part of the breast
Waist	Measure around the natural waistline
Hips	Measure around the fullest part of the body at the top of the hip

Table 2-6 provides a guide for determining the correct size to order through JUMS. Occasionally, vendors producing for the Navy Exchange Command (NEXCOM) and Defense Supply Center Philadelphia (DSCP) may change the lettering convention used to determine size. In Table 2-6, “J” identifies juniors’ sizes, “W” identifies women’s sizes, and “M” identifies misses’ sizes. The description in the JUMS includes, but may not be limited to, the following additional size designations:

- M Misses
- P Petite
- R Regular
- T Tall

**ISSUE CONTROL**

Cadets and their parents or guardians will be required to sign a JUMS generated custody card upon issue of clothing. These receipts will be filed in the local record maintained for each cadet. Figure 2-1 is a sample of the JUMS produced custody card.

**Table 2-6. Women's Body Measurement Chart**

<b>SIZE</b>	<b>BUST MEASUREMENT</b>	<b>WAIST MEASUREMENT</b>	<b>HIP MEASUREMENT</b>
4	32 <sup>1</sup> / <sub>2</sub>	24 <sup>1</sup> / <sub>2</sub>	35
6	33 <sup>1</sup> / <sub>2</sub>	25 <sup>1</sup> / <sub>2</sub>	36
6W	33 <sup>1</sup> / <sub>2</sub>	25 <sup>1</sup> / <sub>2</sub>	38
8	34 <sup>1</sup> / <sub>2</sub>	26 <sup>1</sup> / <sub>2</sub>	37
8W	34 <sup>1</sup> / <sub>2</sub>	26 <sup>1</sup> / <sub>2</sub>	39
10J	36	28	36 <sup>1</sup> / <sub>2</sub>
10	36	28	38 <sup>1</sup> / <sub>2</sub>
10W	36	28	40 <sup>1</sup> / <sub>2</sub>
12J	37 <sup>1</sup> / <sub>2</sub>	29 <sup>1</sup> / <sub>2</sub>	38
12	37 <sup>1</sup> / <sub>2</sub>	29 <sup>1</sup> / <sub>2</sub>	40
12W	37 <sup>1</sup> / <sub>2</sub>	29 <sup>1</sup> / <sub>2</sub>	42
14J	39	31	39 <sup>1</sup> / <sub>2</sub>
14	39	31	41 <sup>1</sup> / <sub>2</sub>
14W	39	31	43 <sup>1</sup> / <sub>2</sub>
16J	41	33	41 <sup>1</sup> / <sub>2</sub>
16	41	33	43 <sup>1</sup> / <sub>2</sub>
16W	41	33	45 <sup>1</sup> / <sub>2</sub>
18	43	35	45 <sup>1</sup> / <sub>2</sub>
18W	43	35	47 <sup>1</sup> / <sub>2</sub>
20	45	37	47 <sup>1</sup> / <sub>2</sub>

**Figure 2-1. Custody Card**

<b>CUSTODY CARD</b>
---------------------

Name: Bud, Harley B.  
 ID: 002438  
 SSN: 123-45-6789

ITEM DESCRIPTION	ITEM TAG	ISSUE DATE	RETURN DATE	UNIT PRICE	CADET INITIALS
COVER SV HAT WHT CNT M		9/10/2004	/ /	\$5.00	
FRAME SERVICE HAT 6 7/8		9/10/2004	/ /	\$7.95	
JACKET RELAXED SDB 42R		9/10/2004	/ /	\$68.00	
SHIRT BLK P/W 14 ½ x 32		9/10/2004	/ /	\$21.00	
SHIRT WHT L/S 14 ½ x 32/33		9/10/2004	/ /	\$20.50	
SHOE DRS BLK LTHR OXF 10.5C		9/10/2004	/ /	\$39.85	
TROUS SV DRS BLU P/W 29 R		9/10/2004	/ /	\$26.60	
<b>TOTAL PRICE:</b>				<b>\$188.90</b>	

I acknowledge receipt of the clothing and equipment listed above for which I have initialed, and I hold myself responsible. I understand that the clothing and equipment are the property of the U.S. Government, and that they are to be returned to the Navy.

Date: \_\_\_\_\_ Cadet's Signature: \_\_\_\_\_

I accept responsibility for the items issued to my son/daughter/ward. I understand the items are U.S. Government property, and that they are to be returned to the Navy. I voluntarily agree to reimburse the U.S. Government for the value of any such items that may be lost or mutilated through misconduct or carelessness.

Date: \_\_\_\_\_ Parent/Guardian's Signature: \_\_\_\_\_

## RETURN OF UNIFORMS

Cadets are required to return all uniform items to the unit Minor Property Custodian (MPC) upon completing or disenrolling from the Naval Science course. The SNSI will make diligent efforts to recover all issued clothing from disenrolled cadets.

In the event clothing is not recovered or is returned damaged, the cadet will make restitution. In determining the amount of restitution, SNSIs will consider such factors as item condition, fair wear and tear, fair value based on replacement cost, and consistency with school policy. Restitution is made by certified check or money order made payable to the "Treasurer of the United States" and delivered to the SNSI. The SNSI will forward the check or money order and a JUMS generated survey to NSTC (NJROTC Supply), 250 Dallas St., Suite A, Pensacola, FL 32508-5268 via the Area Manager. If neither recovery nor restitution is effected, the appropriate school authorities will be notified.

*It is essential that checks/money orders be within 45 days of the issue date when sending to NSTC to ensure ample processing time by DFAS. Checks/money orders that do not meet this requirement will be returned for reissue.*

Clothing deemed unfit for reissue because of normal wear and tear will be surveyed via JUMS following the procedures in chapter 9 of this manual. On average a unit can anticipate surveying up to 25% of the clothing inventory annually.

## ALTERATIONS TO UNIFORMS

Certain minor alterations, such as the adjustment of sleeve length or waist size, may be necessary. Alterations include the attachment of insignia, minor repair of uniforms to be reissued, and cleaning or laundering in preparation for storage. Alterations are limited by the availability of funding but generally average \$14.00 to \$15.00 per cadet for each fiscal year (1 October through 30 September). Reimbursement is not authorized for routine uniform cleaning, which is the responsibility of the cadet during the school year.

## ORGANIZATIONAL ITEMS

Organizational items (Table 2-7) are not considered part of the male or female uniform allowance for costing purposes, nor are they included in the allowable cost of the cadet uniforms. These items are ordered, controlled, and issued using the same procedures that are used for uniform issue. These items are issued to cadets as required.

*Table 2-7. Organizational Items*

NOMENCLATURE	NSN	QTY	REMARKS
Leggings, white	8440-00-261-4260	1	For drill team only
Sword	8455-LL-L00-1052	6	

**Sword Allowance** - Swords may be issued only to cadets in the grade of lieutenant (junior grade) and above. Six swords are authorized for either a company or battalion size unit (100 or more students).

## UNIT FLAG DESIGN

Upon establishment, each new unit will receive a Navy organizational flag, gold and blue bunting, and gold twisted fringe. It is from this generic flag that the unit flag is constructed. Lettering for the unit flag is cut from gold bunting and sewn to the blue bunting background. Figure 2-2 provides detailed directions for construction.

*Figure 2-2. NJROTC Unit Flag Design*

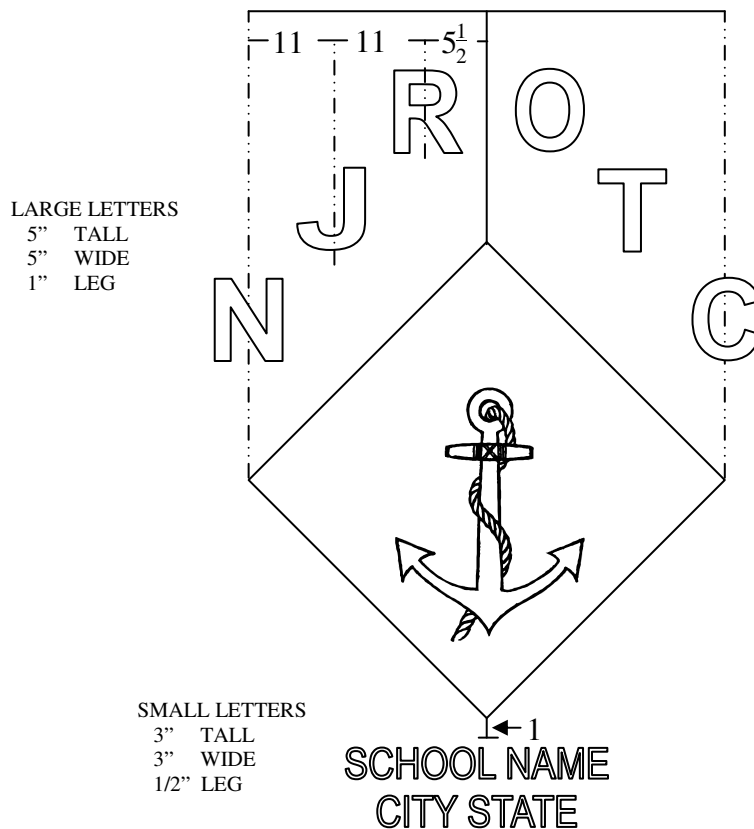

### DIRECTIONS:

1. Since flags vary in size, lay letters out before sewing
2. Use anchor emblem as basis for placement of letters, not the border of the flag.
3. Letters are to be cut from the yellow material and sewn directly onto the front of the flag. Sew reverse side letters to the blue material, then sew the blue material to the flag. This procedure covers the yellow thread from the front letters.
4. Use the large (5") letters for NJROTC and the small (3") letters for the school name.
5. Place no more than 22 small letters (with 1/2" spacing) along the bottom lines of the flag for the school name, city, and state.



## CHAPTER 3: PUBLICATIONS AND INSTRUCTIONAL MATERIAL

### GENERAL INFORMATION

Each NJROTC unit is provided with an initial allowance of instructional material such as publications and training aids when the unit is established. Thereafter, the JUMS generated Annual Instructional Material Report (AIMR) is used to manage the allowance of instructional material needed to replenish a unit's inventory for subsequent school years, taking into account the unit's on-hand inventory and items to be surveyed (unusable/lost). The AIMR will be submitted by each NJROTC unit to NJROTC Supply via the Area Manager's Office annually. The exact due date (usually, mid-January timeframe) will be issued via official email. For requests at other times during the year or for instructional material items not included on the AIMR, units should contact their NJROTC Supply Technician.

### NJROTC REGULATIONS

CNET Instruction 1533.9 series governs the administration of the NJROTC program and is available from NJROTC Supply. Each unit is required to have a current copy of this instruction and NJROTC Official Mail Messages effecting changes to this instruction.

### NJROTC TEXTBOOKS/EQUIPMENT

**General** - Books and materials used in Naval Science courses will be supplied or paid for by the government. All instructional material received will be entered into the JUMS inventory. Table 3-2 is a listing of available items. Table 3-1 details the allowances for those items.

**Issue Control** - All textbooks, non-consumable supplies, and items of equipment issued to NJROTC cadets will be collected by the SNSI annually for reissue. Cadets and their parents or guardians will be required to sign a JUMS generated textbook/equipment custody card upon issue of books and other materials. These receipts will be filed in the local record maintained for each cadet. Figure 3-1 is a sample of the JUMS produced textbook/equipment receipt.

The cadet will make restitution in the event that textbooks are lost or damaged. Restitution is made by certified check or money order made payable to the "Treasurer of the United States" and delivered to the SNSI. The SNSI will forward the check or money order and a JUMS generated survey to the Area Manager. In determining the amount of restitution, SNSIs will consider such factors as item condition, fair wear and tear, fair value based on replacement cost, and consistency with school policy. If neither recovery nor restitution is made, the appropriate school authorities will be notified.

All textbooks or other non-consumable items not available for re-issue must be surveyed in JUMS in order for replacement to be warranted.

**NOTETAKING SHEETS**

Notetaking sheets are not available as a printed item; however, they are available on the applicable curriculum CDs.

*Figure 3-1. Sample JUMS NJROTC Textbook/Equipment Receipt (in JUMS)*

**TEXTBOOK RECEIPT**

Name: BRATLEY, BILL G.  
ID: 0002495  
SSN: 265-10-7210

<u>ITEM TAG</u>	<u>ISSUE DATE</u>	<u>ISSUE CONDITION</u>	<u>UNIT PRICE</u>	<u>CADET INITIALS</u>	<u>RETURN CONDITION</u>	<u>RETURN DATE</u>	<u>INSTRUCTOR INITIALS</u>
NJROTC: NAVAL KNOWLEDGE/NAVAL SKILLS (NS-3 TEXT) (AUG 2003)							
	05/24/2003	NEW	24.44			/ /	
MARITIME HISTORY AND NAVAL SCIENCE (NS-2 TEXT) (AUG 2006)							
	05/24/2006	SATISFACTORY	23.96			/ /	

Total Price: \$48.40

I acknowledge receipt of the textbooks listed above for which I hold myself responsible. I understand that the textbooks are the property of the U.S. Government and that they are to be returned to the Navy. I pledge to keep them clean and in a protected condition.

Cadet's Signature: \_\_\_\_\_ Date: \_\_\_\_\_

I accept responsibility for the items issued to my son/daughter/ward. I understand they are the property of the U.S. Government, and that they are to be returned to the Navy. I voluntarily agree to reimburse the U.S. Government for the value of any such item that may be lost or mutilated through misconduct or carelessness.

Parent/Guardian Signature: \_\_\_\_\_ Date: \_\_\_\_\_



**Table 3-1. Instructional Material Allowances**

National Imagery and Mapping Agency (NIMA) Maps & Charts not specifically listed below	2 per unit
Plotting Sheets: Fictitious Land Areas NW AND SE (100 sheets/pad)	3 pads per unit
Plotting Sheets: Maneuvering Board (50 sheets/pad)	5 pads per unit
North Pacific Wilkes Island (Port Maury)	25 per unit
Wall Charts	2 per unit
Maneuvering Board (available only to units teaching maneuvering – ordered via special request to NJROTC Supply via Area Manager)	1 per unit
Required textbooks; <u>The Maneuvering Board: A Revised Course of Programmed Instruction</u>	125% of course enrollment
Cadet Field Manual	125% of NS-1 enrollment
Curriculum outlines, barcoded instructor guides, instructor study question guides, DVDs, CDs	2 per unit for NS-1 & 2 1 per unit for NS-3 & 4
*All reference material, unless otherwise noted (e.g. <u>Knight's Modern Seamanship</u> , <u>Dutton's Navigation &amp; Piloting</u> , <u>Bluejacket's Manual</u>	1 per unit
<u>Ethics for the Junior Officer</u>	2 per unit
<u>National Standard 3-Position Air Rifle Rules</u> , <u>The Orienteering Handbook</u> , <u>NJROTC Jr. Position Air Rifle Student Handbook</u>	20 per unit
<u>NJROTC Basic Leadership Training (BLT) Instructor Guide</u>	1 per BLT instructor
<u>Barron's ASVAB, ACT, and SAT</u>	5 per unit
<u>NJROTC Recruiting Pamphlet</u> (250 per pack)	2 packs per unit
<u>NJROTC Fact Sheet</u> (100 per pack)	5 packs per unit
<u>NJROTC Book Covers</u> (100 per pack)	2 packs per unit
Training Aids: World Globe; Map, Geographic of the U.S; Map, Geographic of the World;	1 per classroom
Training Aids: Magnetic Compass; Triangle, Drafting, Plastic	20 per unit
Training Aids: Drafting Divider, Parallel Ruler	40 per unit
Training Aids: Easel, Display and Training; Marine Training Sextant	1 per unit
Training Aid: Signal Flag Card Deck	2 per unit

*\*Reference books are not replaced yearly and units ordering these items may not receive the most current editions. New editions are not issued until stock of older edition has been depleted.*

**Table 3-2. Instructional Material Detailed Listing**

<b>NSN</b>	<b>DESCRIPTION</b>
	<b>MAPS AND CHARTS</b>
7642014009433	No. 1 Nautical Charts, Symbols, & Abbreviations WOBZC1
7643014045397	No. 1145 Chart of The World
7642014014635	Light List, Atlantic Coast M165022
7642014009416	No. 17 Great Circle Sailing Chart, Atlantic 017NAV/OP
7642014009510	No. 56 Great Circle Sailing Chart, Pacific 056NAV/OP
7642014009444	No. 76 Time Zone Chart Of The World 076NAV/OP
	<b>PLOTTING SHEETS</b>
0509LP0420625	Fictitious Land Areas Northwest (100 sheets per pad) NAVEDTRA 37083
0509LP0420626	Fictitious Land Areas, Southeast (100 sheets per pad) NAVEDTRA 37084
7642014009445	Maneuvering Board (50 sheets per pad) 509NAV/OP
7642014009585	North Pacific Wilkes Island (Port Maury) 099NAV/OP
	<b>WALL CHARTS</b>
0503LP2198100	Armed Forces Decorations and Awards Booklet NAVEDTRA 46408A
0503LP4797800	Armed Forces Insignia Poster NAVEDTRA 46200-D
	<b>NAVAL SCIENCE 1 BOOKS</b>
0509LP1037834	NS-1 Introduction Text NAVEDTRA 37125-B (2005)
0509LP1037835	NS-1 Introduction DVD Barcoded Instructor Guide NAVEDTRA 37126-B (2005)
0509LP1037839	NS-1 Introduction Curriculum Outline NAVEDTRA 37133-B
0509LP1031173	Cadet Field Manual NAVEDTRA 37116-F (2005)
0509LP1037837	Cadet Field Manual DVD Barcoded Instructor Guide NAVEDTRA 37129-F (2005)
0509LP1037840	Cadet Field Manual Curriculum Outline NAVEDTRA 37128-F (2005)
7020NS1CFMDVD	NS-1 Introduction and Cadet Field Manual DVD Disk (2005)
7020NS1CFMCUR	NS-1 Introduction and Cadet Field Manual Curriculum CD (Test Banks, Curriculum Outline, Notetaking Sheets) (2005)
	<b>NAVAL SCIENCE 2 BOOKS</b>
0509LP1048045	NS-2 Text, Maritime History and Naval Science for the NJROTC Student (2006)
0509LP1048048	NS-2 Instructor Study Question Guide (2006)
0509LP1048052	NS-2 Curriculum Outline NAVEDTRA 37137-B (2006)
0509LP1048055	NS-2 DVD Barcoded Instructor Guide NAVEDTRA 37138-B (2006)
7020NS2DVD006	NS-2 DVD Disk NAVEDTRA 37141-B (2006)
7020NS2CURCD6	NS-2 Curriculum CD (Test Banks, Curriculum Outline, Notetaking Sheets) NAVEDTRA 37142-B (2006)

Table 3-2. Instructional Material Detailed Listing (Cont'd)

NSN	NAVAL SCIENCE 3 BOOKS
0509LP1018874	NS-3 Text, Naval Knowledge and Naval Skills
0509LP1018879	NS-3 Instructor Guide
0509LP1018882	NS-3 Curriculum Outline NAVEDTRA 37106-D
7020CDNS3CURR	NS-3 Curriculum CD (Test Banks, Curriculum Outline, Notetaking Sheets)
0509LP1018888	NS-3 DVD Barcoded Instructor Guide for Naval Knowledge NAVEDTRA 37145
7020DVDNS03NK	DVD Disk for NS-3 Naval Knowledge
7020GAMENS3NK	Game CD for NS-3 Naval Knowledge
0509LP1018890	NS-3 DVD Barcoded Instructor Guide for Naval Skills NAVEDTRA 37146
7020DVDNS03NS	DVD Disk for NS-3 Naval Skills
7020GAMENS3NS	Game CD for NS-3 Naval Skills
0509LP0420553	The Maneuvering Board, A Programmed Instruction (optional item)
	<b>NAVAL SCIENCE 4 BOOKS</b>
0509LP4804600	NS-4, Selected Readings in Naval Leadership For The NJ Student
0509LP4804700	Ethics For The Junior Officer
0509LP4804800	NS-4 Instructor Guide NAVEDTRA 37103-A (1995)
0509LP4804801	NS-4 Instructor Guide NAVEDTRA 37103-A CH-1 (Feb 97)
0509LP4804802	NS-4 Instructor Guide NAVEDTRA 37103-A CH-2 (Oct 98)
0509LP4805000	NS-4 Curriculum Outline NAVEDTRA 37107-A (1995)
0509LP4805001	NS-4 Curriculum Outline 37107-A CH-1 (Feb 97)
NONE4A	NS-4 Instructor's Answer Guide Selected Readings in Naval Leadership
	<b>*REFERENCES</b>
NONE5	Barron's ASVAB
NONE6	Barron's ACT
NONE7I	Barron's SAT
NONE22	The Bluejacket's Manual
0509LP0420121	Fundamentals of Naval Leadership
0509LP0420141	Influence of Sea Power Upon History
0509LP2157100	Knight's Modern Seamanship
7642015152748	Nautical Almanac – <a href="#">on auto refresh</a>
0509LP0420075	Naval Ceremonies, Customs and Traditions
0509LP0420210	Dutton's Navigation and Piloting
7642014482151	Navigation Rules, International-Inland
0509LP0420474	Sea Power: A Naval History
0509LP4783800	Ships & Aircraft of the U.S. Fleet
NONEBOOK01	The Greatest Generation
NONEBOOK02	Flags of Our Fathers
NONEBOOK03	It's Your Ship: Management Techniques from the Best Damn Ship in the Navy
NONEBOOK04	Thunder Below!: The USS *Barb* Revolutionizes Submarine Warfare in World War II

*\*Reference books are not replaced yearly and units ordering these items may not receive the most current editions. New editions are not issued until stock of older edition has been depleted.*

Table 3-2. Instructional Material Detailed Listing (Cont'd)

<b>SPECIAL PUBLICATIONS</b>	
0509LPAIR0001	National Standard 3-Position Air Rifle Rules
0509LP0420573	Seamanship: Fundamentals for The Deck Officer
0509LP0420003	The Orienteering Handbook
0509LP0222890	NJROTC Recruiting Pamphlet (250 per Package)
0509LP1002207	NJROTC Book Covers NAVEDTRA 37131 (2001) (100 per Package)
0509LP4770900	NJROTC Fact Sheet (100 per Package)
<a href="#">0509LP1047153</a>	<a href="#">NJROTC Junior Position Air Rifle Student Handbook</a>
<a href="#">37118-A</a>	<a href="#">NJROTC Basic Leadership Training (BLT) Instructor Guide (2004)</a>
<b>MISCELLANEOUS TRAINING AIDS</b>	
012NAV/OP	World Globe, 12-inch
018NAV/OP	Map: Geographic of the U.S, Large Wall
019NAV/OP	Map: Geographic of the World, Large Wall
6605002405717	Maneuvering Board, small, non-magnetic
6605005538795	Magnetic Compass
6675001905867	Triangle, Drafting, Plastic
6675001911507	Parallel Ruler
6675002435015	Drafting Divider
7520014244845	Easel, Display and Training
6910005142033	Signal Flag Card Deck
6930002921348	Marine Training Sextant

## CHAPTER 4: FORMS

### FORMS LIST

Many of the forms previously required by the NJROTC unit are now automatically produced in JUMS. The Area Manager stocks forms unique to NJROTC, or the Navy, that are not produced in JUMS; these are ordered [from the Area Manager/NJROTC Portal](#) by the SNSI via email. In addition, some forms are available in electronic format on the NJROTC Program's Web Portal's download section. You need to be registered as an instructor on the portal and signed-in, and go to the Instructor Zone > Portal Downloads > Download Data Base > NJROTC Forms > Cadet Certificates or click on the following Portal Downloads link. Current address is: <http://www.navyjrotc.us/portal/dload.php?action=category&cat id=5>

**Table 4-1 Generally Required Forms**

FORM NUMBER	TITLE	SOURCE
CNET 1020/1	Female Clothing Issue	JUMS
CNET 1020/2	Male Clothing Issue	JUMS
CNET 1533/3	NJROTC Student Record	JUMS
CNET 1533/37	NJROTC Answer Sheets	NSTC
CNET 1533/52	NJROTC Textbook/Equipment Receipt	JUMS
CNET 1533/61	NJROTC Ribbon Poster	Area Manager
CNET 1533/106	NJROTC Health Risk Screening Questionnaire	Area Manager/ <b>NJROTC Portal</b>
CNET 1650/1	NJROTC Certificate of Completion 4 Courses	<b>NJROTC Portal</b>
CNET 1650/2	NJROTC Certificate of Completion 3 Courses	<b>NJROTC Portal</b>
CNET 1650/3	NJROTC Certificate of Completion 2 Courses	<b>NJROTC Portal</b>
CNET 1650/4	NJROTC Certificate of Completion 1 Course	<b>NJROTC Portal</b>
CNET 1650/5	Certificate of Special Commendation	<b>NJROTC Portal</b>
CNET 1650/6	Certificate of Appreciation	<b>NJROTC Portal</b>
CNET 1650/9	Distinguished Cadet Certificate	<b>NJROTC Portal</b>
CNET 1650/11	Certificate of Promotion	<b>NJROTC Portal</b>
CNET 1650/12	Certificate of Meritorious Achievement	<b>NJROTC Portal</b>
CNET 1650/14	Cadet of the Month	<b>NJROTC Portal</b>
CNET 1650/21	<a href="#">Distinguished Unit Award</a>	Ordered by Area Manger from NSTC
CNET 1650/32	Certificate of Completion of Leadership Academy	<b>NJROTC Portal</b>
CNET 1650/43	Certificate of Cadet Achievement	<b>NJROTC Portal</b>
CNET 5800/4	NJROTC Standard Release Form	Area Manager/ <b>NJROTC Portal</b>
DD200	Report of Survey	JUMS
DD2754	JROTC Instructor Annual Certification of Pay and Data	NSTC/ <b>NJROTC Portal</b>

DD2767	JROTC Instructor Annual Certification Worksheet for Entitlement Computation	NSTC/ <b>NJROTC Portal</b>
SF 1034	Voucher for Purchases and Services Other Than Personal	NSTC provided <a href="#">via pdf as necessary</a>

## CHAPTER 5: VIDEO TRAINING AIDS

### ALLOWANCE

NSTC (NJROTC) establishes the NJROTC unit training aids allowance. Sources of training aid support for NJROTC units are Naval Service Training Command (NSTC); the Naval Education and Training Professional Development Training Center (NETPDTC), Pensacola, FL; and the Electronic Media Center (EMC) Norfolk, VA. Those items provided by NETPDTC, Pensacola are listed in the Instructional material Module of JUMS. The NJROTC Department/Saufley Field Warehouse provides the initial outfitting and replacement of material listed in table 5-1.

### ORDERING

All videotapes/DVDs are initially provided as part of the unit's start-up kit. NJROTC units requiring replacement DVD/videotapes should email their Area Managers with the following information: complete mailing address; UIC; point of contact; telephone number; Stock Number and Title of required selection, and reason for required replacement. The Area Manager, after reviewing the unit's request, will forward the email to NJROTC Supply for processing.

Table 5-1 lists those videotapes that are issued automatically to all NJROTC units upon startup and allowance is one per unit. Replacements can be ordered via the Area Manager. The videos/DVDs listed in Table 5-1 are the **only** titles approved for use by the NJROTC units. Please note that the lists of videos contained in the NJROTC Curriculum Outlines are not issued by NSTC (unless listed in Table 5-1). SNSI's may order those titles directly from the Defense Automated Visual Information System/Defense Instructional Technology Information System (DAVIS/DITIS) website: <http://dodimagery.afis.osd.mil/davis/>

**Table 5-1. Videotapes/CD's/DVD's**

<b>STOCK NUMBER</b>	<b>TITLES</b>
<b>NONEDVD-01*</b>	<b>The War of Independence 1775-1783 RT: 23:00, The War of 1812 RT:20:00, The Civil War Part 1 RT: 18:00, The Civil War Part 2 RT: 19:00</b>
<b>NONEDVD-02*</b>	<b>Men With Green Faces RT: 26:30, Desert Survival RT: 27:00, Land Navigation-Walking Out RT: 25:00, Desert Storm-Navy-Marine Corps Team RT: 19:00</b>
<b>NONEDVD-03*</b>	<b>NJROTC Platoon Drill-Parts 1, 2, 3 Part 1 RT: 9:00/Part 2 RT: 19:00/Part 3 RT: 14:30. NJROTC Individual &amp; Squad Drill-Parts 1, 2, 3 Part 1 RT: 10:00/ Part 2 RT:12:00/ Part 3 RT: 11:00</b>
<b>NONEDVD-04*</b>	<b>Be Someone Special RT: 23:00, 21<sup>st</sup> Century Navy RT: 9:42, NJROTC Leadership Academy 22 Vignettes</b>
<b>NONEDVD-05*</b>	<b>Be Someone Special Be a NJROTC Cadet RT: 18:00 The NJROTC Program RT: 8:00</b>
<b>7020DRILL2006*</b>	<b>NJROTC DVD Includes The Sword Manual, The Manual of Arms, The Color Guard, and The Guidon Manual</b>
<b>NONEDVD-5*</b>	<b>Seabiscuit</b>
<b>NONEDVD-6*</b>	<b>Gettysburg</b>
<b>NONEDVD-7*</b>	<b>Hoosiers</b>
<b>NONEDVD-8*</b>	<b>Remember The Titans</b>
<b>NONEDVD-9*</b>	<b>Tuskegee Airmen</b>
<b>NONEDVD-10*</b>	<b>Windtalkers</b>
<b>NONEDVD-11*</b>	<b>*Mister Roberts</b>
<b>NONEDVD-12*</b>	<b>*Many Faces of Old Glory</b>
<b>NONEDVD-13*</b>	<b>*The Caine Mutiny</b>
<b>NONEDVD-14*</b>	<b>*12 O'clock High</b>
<b>NONEDVD-15*</b>	<b>*Bridge on the River Kwai</b>
<b>NONEDVD-16*</b>	<b>*Taps</b>
<b>NONEDVD-17*</b>	<b>*Bridges of Toko-Ri</b>
<b>NONEVHS-1</b>	<b>Nova Aircraft Carrier</b>
<b>NONEVHS-2</b>	<b>Glory</b>
<b>NONEVHS-3</b>	<b>Command Decision</b>

\* Titles with asterisks available in DVD; all others available in VHS only.



## CHAPTER 6 : AUDIOVISUAL/INFORMATION TECHNOLOGY EQUIPMENT

### ALLOWANCES

The NJROTC unit audiovisual equipment and information technology (computer related) equipment allowance lists are established by NSTC (NJROTC). This equipment is provided to a unit when it is established and is refreshed periodically as budget permits. Requests for additional equipment must include a complete justification, and should be submitted by email to NSTC (NJROTC Supply) via the Area Manager. The NJROTC unit audiovisual equipment allowance is shown in table 6-1 and information technology equipment allowance is shown in table 6-2.

**Table 6-1. Audiovisual Equipment Allowance**

NOMENCLATURE	QUANTITY
Cassette/CD Player/Recorder	1 each (per classroom)
Video Cassette Player/Recorder VHS	1 each
Color TV Receiver	2 each (per classroom)
TV Stand	2 each (per classroom)
Camcorder	1 each
Camcorder Tripod	1 each
DVD Player	1 each (per classroom)
Barcode Reader	1 each (per classroom)
Loudspeaker (Bullhorn)	1 each
Multimedia Converter	1 each (per classroom)
Anti-Theft Device	10 each

**Table 6-2. Information Technology Equipment Allowance**

NOMENCLATURE	QUANTITY
Computer (CPU & Keyboard, Mouse, Speakers)	3 each
Computer Monitor (Size may vary)	3 each
Printer (Types may vary)	2 each
Back Up Device CDR/W (may be internal or external)	1 each



## CHAPTER 7: DRILL RIFLES

Each NJROTC unit SNSI is encouraged to conduct training in rifle drill, and each unit has an allowance of drill rifles to perform this training. This chapter provides the procedures and guidance for acquiring, maintaining, storing, and disposing of drill rifles.

### ALLOWANCE

Naval Sea Systems Command (NAVSEA) has authorized NSTC an allowance of drill rifles for use in the NJROTC program. Starting with the FY-00 expansion all new NJROTC units are authorized 30 drill rifles, with some units being increased or decreased depending on enrollment or other justification. Authorized drill rifles are listed in Table 7-1.

*Table 7-1. Authorized Dummy Drill Rifles*

NSN	DESCRIPTION
1005-00-109-5682	Rifle, Dummy Drill, MK5-0 (Non-operational bolt)
1005-01-069-8565	Rifle, Dummy Drill, MK5-1 (Operational bolt)
1005-01-120-5389	Rifle, Dummy Drill, MK6-0 (Non-operational bolt)
1005-LL-L00-1903	Rifle, Dummy Drill, Daisy Facsimile 1903

The MK 5 Drill Rifle is a demilitarized 1903 Springfield rifle. The MK 6 Drill Rifle is a demilitarized M1 rifle. The Daisy Facsimile Drill Rifle is a replica of the 1903 Springfield, not a demilitarized weapon. The MK6 Mod 1 Drill Rifle is specifically not authorized for use by NJROTC units. [By the end of FY06, all units will have received an initial issue of 30 Daisy facsimile drill rifles and phase out of other drill rifle models will begin.](#)

### ALLOWANCE CHANGES

Units requesting allowance changes (increase, decrease or deletion of allowance), must submit email request to NJROTC Supply via the Area Manager. However, under no circumstances, can the overall NSTC allowance be exceeded. An allowance change request will include UIC, NSN, description, current allowance, requested allowance, and a detailed justification.

Increased allowances are filled from within the NJROTC Program (i.e. from another unit). Excess drill rifles caused by a decreased allowance will be [made available by](#) NSTC for redistribution to other.

## **INVENTORY**

The annual Drill Rifle Inventory is included in the Military Supply Wall to Wall Inventory, due 15 April each calendar year. A JUMS generated survey is required for all gains and losses of drill rifles (this is to ensure proper accounting of the drill rifles).

## **SURVEY OF DRILL RIFLES**

A JUMS generated survey is required whenever a drill rifle is lost, stolen, damaged beyond repair (when the barrel is broken) or recovered. For information on completing a JUMS survey form, see chapter 9. After completing the survey, the SNSI will forward it to the Area Manager for review and approval. After approval, the Area Manager will forward the survey to the following address:

Commander, Naval Service Training Command  
NJROTC Program, Code: CD23  
250 Dallas Street  
Pensacola, FL 32508-5268

## **RETURN OF DRILL RIFLES**

All drill rifles are to be returned to Commander, Naval Service Training Command [when](#):

Excessive quantity over and beyond authorized allowance ([requires prior approval from NSTC](#)).

Elimination of Authorization of Drill Rifle Program

Disestablishment of the NJROTC unit

Reduction in size of unit

Any reason not covered above requires Area Manager and NSTC approval

Return all drill rifles (regardless of condition) to the following address:

Supply Officer NAS Pensacola  
Shipping Department BLDG 3581  
MARK FOR: NJROTC  
690 San Carlos Road  
Pensacola FL 32508-5014

## **DISPOSITION INSTRUCTIONS**

The SNSI will contact the Area Manager and NJROTC Supply for disposition instructions. NJROTC Supply will provide shipping documentation and determine the best method of return. All drill rifles will require a DD-1149 shipping document to accompany the drill rifles.

## **TRANSFER OF DRILL RIFLES BETWEEN UNITS**

On occasion units will request to transfer excess drill rifles to another nearby unit. When this occurs the SNSI will contact the Area Manager and NJROTC Supply for approval and shipping instructions if required. All transfers will be accomplished via JUMS by changing the property record to “transferred”. If rifles require shipping NJROTC Supply will provide a DD-1149 to the transferring unit. The following information is required to prepare the DD-1149:

- Complete shipping address of the shipping unit with the SNSI’s name and phone number
- Complete shipping address of supply center conducting the shipping with POC and phone number
- Complete shipping address of the receiving unit with the SNSI’s name and phone number
- Complete listing of drill rifle serial numbers to be transferred

## **SECURITY**

NJROTC drill rifles **will not be removed** from school property except for use at an NJROTC event or with written permission of the SNSI or designated representative.

All models of NJROTC drill rifles have been declared by the Chief of Naval Operation (CNO) to be non-sensitive accountable government property. Security must be stringent enough to preclude loss by theft or pilferage. At the minimum, the drill rifle must be stored in a lockable container or storage rack in an area of limited accessibility, such as unit equipment/clothing storeroom. Several different styles of racks are recommended for storage. Figures 7-4 and 7-5 provide detailed construction instructions.

Privately owned weapons are not authorized to be stored with drill rifles.

## **REPAIR**

It is the responsibility of the NJROTC unit to keep drill rifles in good condition. Because of the type of drill performed, the drill rifle will become damaged and will require replacement of damaged parts. The NJROTC unit must repair damaged drill rifles.

NJROTC instructors may order drill rifle repair parts at no cost to the unit. It should be noted that repair parts for MK5MOD0, MK5MOD1, and MK6MOD0, are being phase out. Once current stock is exhausted, stock will not be replenished. Parts identified with \*\* in figure 7-1 and figure 7-2 are no longer available.

Parts requests will be submitted to NJROTC Supply via the Area Manager by email in spreadsheet format and must list *ITEM, NOMENCLATURE, STOCK NUMBER, and QUANTITY*.

\*\* Note\*\* The barrel is not a replacement part; it is the accountable part of the Drill Rifle.

Figure 7-1. Repair Parts for MK5-0 and MK5-1 Drill Rifles

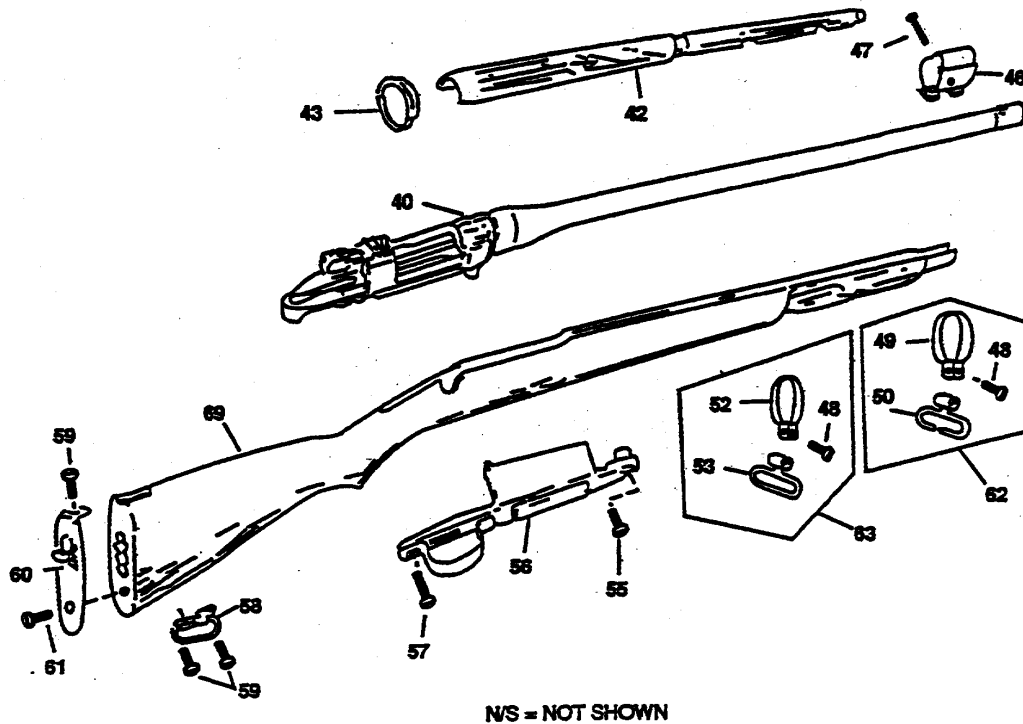

ITEM	NOMENCLATURE	STOCK NUMBER
36 N/S	Sling, black cotton w/ assembly	1005-LL-LS6-3067
36A N/S	Sling, olive drab cotton w/ assembly	1005-LL-LS6-3066
42	Hand guard (plastic)	1005-00-103-5355
43	Ring, barrel guard	1005-00-515-3072
46	Band, bayonet	1005-00-562-1049
47	Screw, bayonet band	5305-00-529-5818
48	Screw, stacking & front sling swivels	5305-LL-LS6-3059
49	Band, stacking swivel	1005-LL-LS6-3060
50	Swivel, stacking	1005-LL-LS6-3061
52	Band, front sling swivel	1005-LL-LS6-3062
53	Swivel, front sling band	1005-LL-LS6-3063
55	Screw, trigger guard, front	5305-00-612-8413
56	Trigger/magazine guard assembly	1005-00-556-4394 **
57	Screw, trigger guard, rear	5305-00-612-8414
58	Swivel, rear sling assembly	1005-00-614-7710
59	Screw, butt plate, top & rear sling assembly	5305-00-614-6873 **
60	Butt plate assembly	1005-00-561-3665
61	Screw, butt plate, bottom	1005-00-612-8412
62	Stacking swivel assembly	1005-00-625-7635
63	Front sling assembly	1005-00-561-3667
69	Stock, plastic	1005-00-103-5434
86 N/S	Recoil pad, rubber. (slip-on)	1005-01-095-8950

Figure 7-2. Repair Parts for MK6-0 Drill Rifle

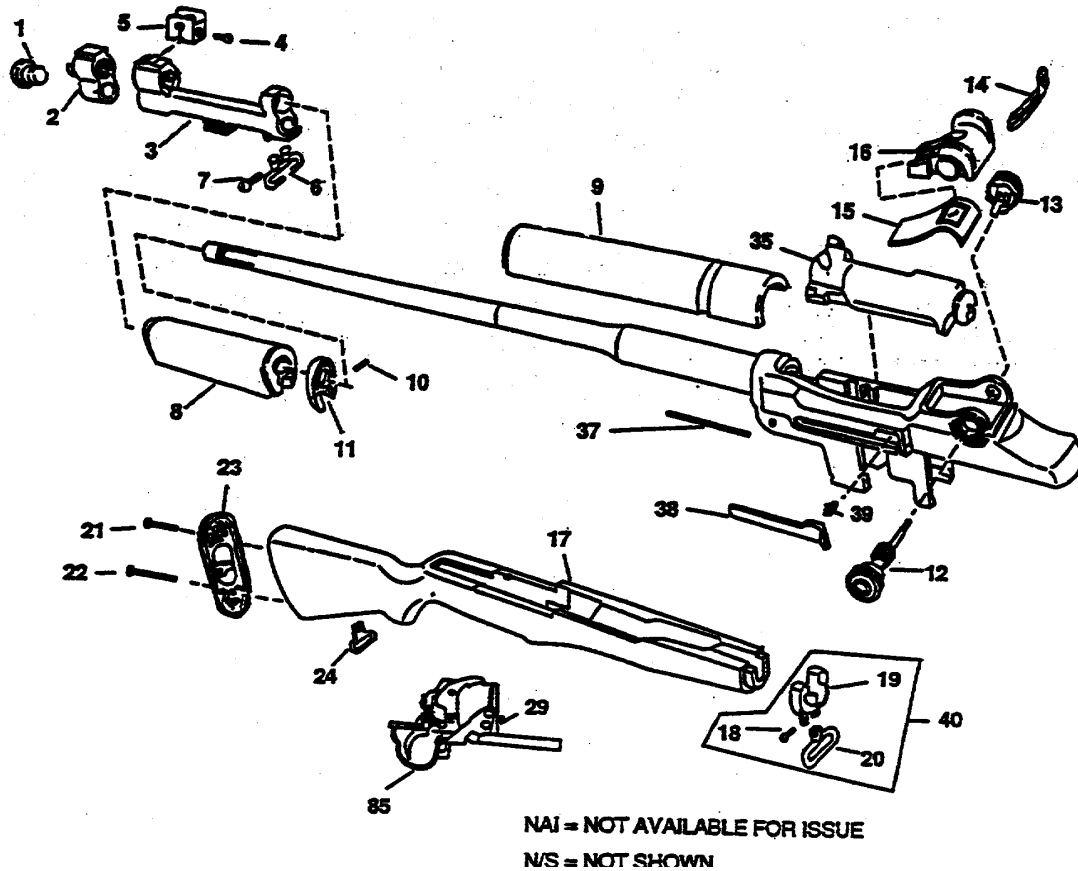

ITEM	DESCRIPTION	NSN
1	Screw, gas cylinder lock	1005-00-313-9441
2	Lock, gas cylinder	1005-00-726-5871
3D	Gas cylinder (w/stack swivel)	1005-LL-LS6-3086
3E	Gas cylinder (w/front sight)	1005-LL-LS6-3087
3G	Gas cylinder (w/front sight & stacking swivel)	1005-LL-LS6-3088
3X	Gas cylinder (modified w/stacking swivel)	1005-LL-LS6-3092
4	Screw, front sight	5305-00-983-6658
5	Front sight	1005-00-614-7427 **
6	Swivel, stacking	1005-00-600-8891
7	Screw, stacking swivel	5305-00-616-4831
8A	Hand guard, front (unfinished wood)	1005-LL-LS6-3075
8B N/S	Spacer, hand guard, front	1005-LL-LS6-3077 **
8C N/S	Ferrule, hand guard, front	1005-LL-LS6-3076
8P	Hand guard, front (plastic)	1005-01-448-5477
9A	Hand guard, rear (unfinished wood)	1005-LL-LS6-3078

\*\* Part no longer available

Figure 7-2. Repair Parts for MK6-0 Drill Rifle (Cont'd)

ITEM	DESCRIPTION	NSN
9B	Clipband, hand guard, rear	1005-LL-LS6-3079
9P	Hand guard, rear (plastic)	1005-01-448-5473
10	Pin spring, lower band	5315-00-058-6079
11	Band, lower, hand guard	1005-00-554-6000 **
12	Elevation pinion, rear sight	1005-00-731-2738
13	Knob windage, rear sight	5355-00-731-3737
14	Aperture, sight	1005-00-600-8868
15	Cover, rear sight	1005-00-600-8872
16	Base, rear sight	1005-00-554-6001
17	Stock, rifle (unfinished wood)	1005-00-653-5467
17P	Stock, rifle (plastic)	1005-01-448-5471 **
18	Screw, front sling swivel	5305-00-501-3677
19	Ferrule, stock	1005-00-554-6013
20	Swivel, front sling	1005-00-600-8890
21	Screw, butt plate top & rear sling assembly	5305-00-614-6873 **
22	Screw, butt plate, bottom	5305-00-600-8881
23	Butt plate assembly	1005-00-556-4283
23R	Butt plate assembly (rubber)	1005-01-448-5467
24	Swivel, rear sling	1005-00-600-8889
36 N/S	Sling, black cotton w/assemble	1005-LL-LS6-3067
36A N/S	Sling, olive drab cotton w/assemble	1005-LL-LS6-3066
37	Pin, latch	5315-00-600-8889
38	Latch	1005-00-564-6011
39	Spring, latch	5360-00-600-8885
40	Front sling swivel assemble	1005-LL-LS6-3085
82 N/S	Pin, trigger guard/hammer	5315-00-501-3668
85	Guard trigger	1005-00731-2631

\*\* Part no longer available



Figure 7-3. Repair Parts for Daisy Drill Rifle 1903

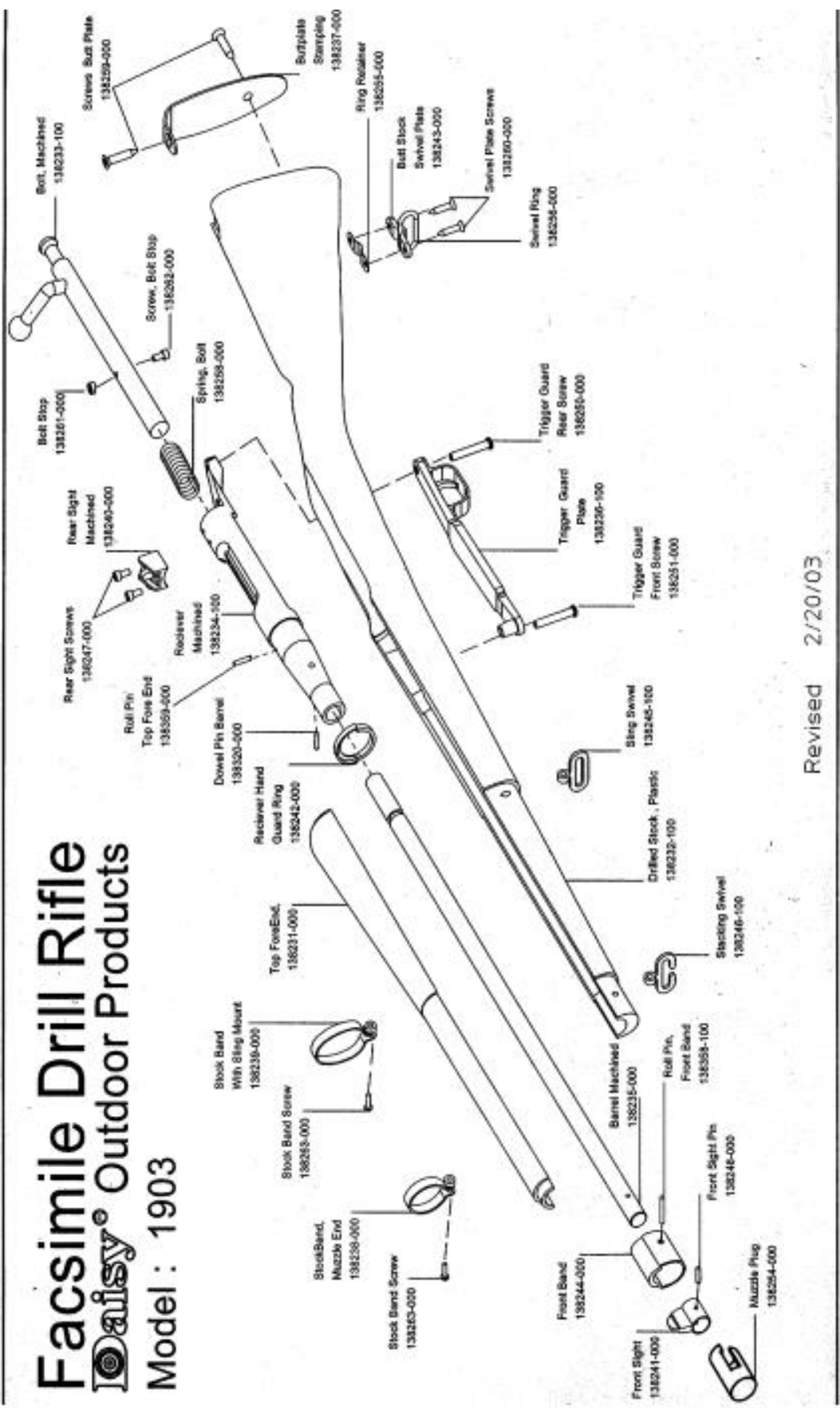

Revised 2/20/03

Figure 7-3. Repair Parts for Daisy Drill Rifle 1903 (Cont'd)

ITEM NUMBER	DESCRIPTION	NSN	QTY
138231-000	Forend, top	1005LLLDD8231	1 each
138232-100	Stock, drilled	1005LLDDD8232	1 each
169807-000	Bolt assembly (contents below)	1005LLLDD9807	1 assembly
<i>138262-000</i>	<i>Screw, bolt stop</i>	<i>Not available individually</i>	<i>1 each</i>
<i>138261-000</i>	<i>Bolt stop</i>	<i>Not available individually</i>	<i>1 each</i>
<i>138233-100</i>	<i>Bolt</i>	<i>Not available individually</i>	<i>1 each</i>
138235-000	Barrel, machined	1005LLLDD8235	1 each
138237-000	Butt plate	1005LLLDD8727	1 each
138384-000	Butt plate, rubberized	1005LLLDD8384	1 each
169808-000	Band, front stock (contents below)	1005LLLDD9808	1 assembly
<i>138238-000</i>	<i>Muzzle-end, stock band</i>	<i>Not available individually</i>	<i>1 each</i>
<i>138263-000</i>	<i>Screw, stock band</i>	<i>Not available individually</i>	<i>1 each</i>
<i>138246-100</i>	<i>Swivel, stacking</i>	<i>Not available individually</i>	<i>1 each</i>
169809-000	Swivel assembly, front (contents below)	1005LLLDD9809	1 assembly
<i>138239-000</i>	<i>Sing mount, stock band</i>	<i>Not available individually</i>	<i>1 each</i>
<i>138263-000</i>	<i>Screw, stock band</i>	<i>Not available individually</i>	<i>1 each</i>
<i>138245-100</i>	<i>Swivel, sling</i>	<i>Not available individually</i>	<i>1 each</i>
138241-100	Sight, front	1005LLLDD8241	1 each
138240-100	Sight, rear	1005LLLDD8240	1 each
169810-000	Swivel assembly, rear (contents below)	1005LLLDD9810	1 assembly
<i>138256-000</i>	<i>Ring, swivel</i>	<i>Not available individually</i>	<i>1 each</i>
<i>138243-000</i>	<i>Plate, butt plate swivel</i>	<i>Not available individually</i>	<i>1 each</i>
<i>138255-000</i>	<i>Ring, retainer</i>	<i>Not available individually</i>	<i>1 each</i>
<i>138260-000</i>	<i>Screw, plate swivel</i>	<i>Not available individually</i>	<i>2 each</i>
138242-100	Ring, receiver hand guard	1005LLLDD8242	1 each
138244-100	Band, front	1005LLLDD8244	1 each
138236-100	Plate, trigger guard	1005LLLDD8236	1 each
138234-100	Receiver	1005LLLDD8234	1 each
138258-000	Bolt, spring	1005LLLDD8258	1 each
138254-000	Plug, muzzle	1005LLLDD8254	1 each
169811-000	Pin/screw, assortment (contents below)	1005LLLDD9811	1 package
<i>138248-000</i>	<i>Pin, front sight</i>	<i>Not available individually</i>	<i>1 each</i>
<i>138358-100</i>	<i>Pin, front band</i>	<i>Not available individually</i>	<i>1 each</i>
<i>138230-000</i>	<i>Pin, barrel</i>	<i>Not available individually</i>	<i>1 each</i>
<i>138359-000</i>	<i>Pin, top forend</i>	<i>Not available individually</i>	<i>1 each</i>
<i>138247-000</i>	<i>Screw, rear sight</i>	<i>Not available individually</i>	<i>2 each</i>
<i>138251-000</i>	<i>Screw, front trigger guard</i>	<i>Not available individually</i>	<i>1 each</i>
<i>138250-000</i>	<i>Screw, rear trigger guard</i>	<i>Not available individually</i>	<i>1 each</i>
<i>138259-000</i>	<i>Screw, butt plate</i>	<i>Not available individually</i>	<i>2 each</i>

Figure 7-4. Wall Style Drill Rifle Storage Rack

**Note**  
 RIFLE RACK TO BE PAINTED OR VARNISHED AFTER  
 ASSEMBLY IS COMPLETED.

**Materials List**

- 1 - 1" x 23" x 95" PLYWOOD
- 1 - 1" x 7" x 95" PLYWOOD
- 2 - 1" x 23" x 45" PLYWOOD
- 4 - 1" x 4" x 95"
- 2 - 1" x 4" x 21"
- 38 - 1" x 4" x 6"

(APP.) 100 - Ø.125 x 1.50LG" WOOD SCREWS

**NOTE:** RACK SHOWN IS FOR THE  
 MK5 DRILL RIFLE, MODIFICATION  
 MAY BE REQUIRED FOR MK6 RIFLES.

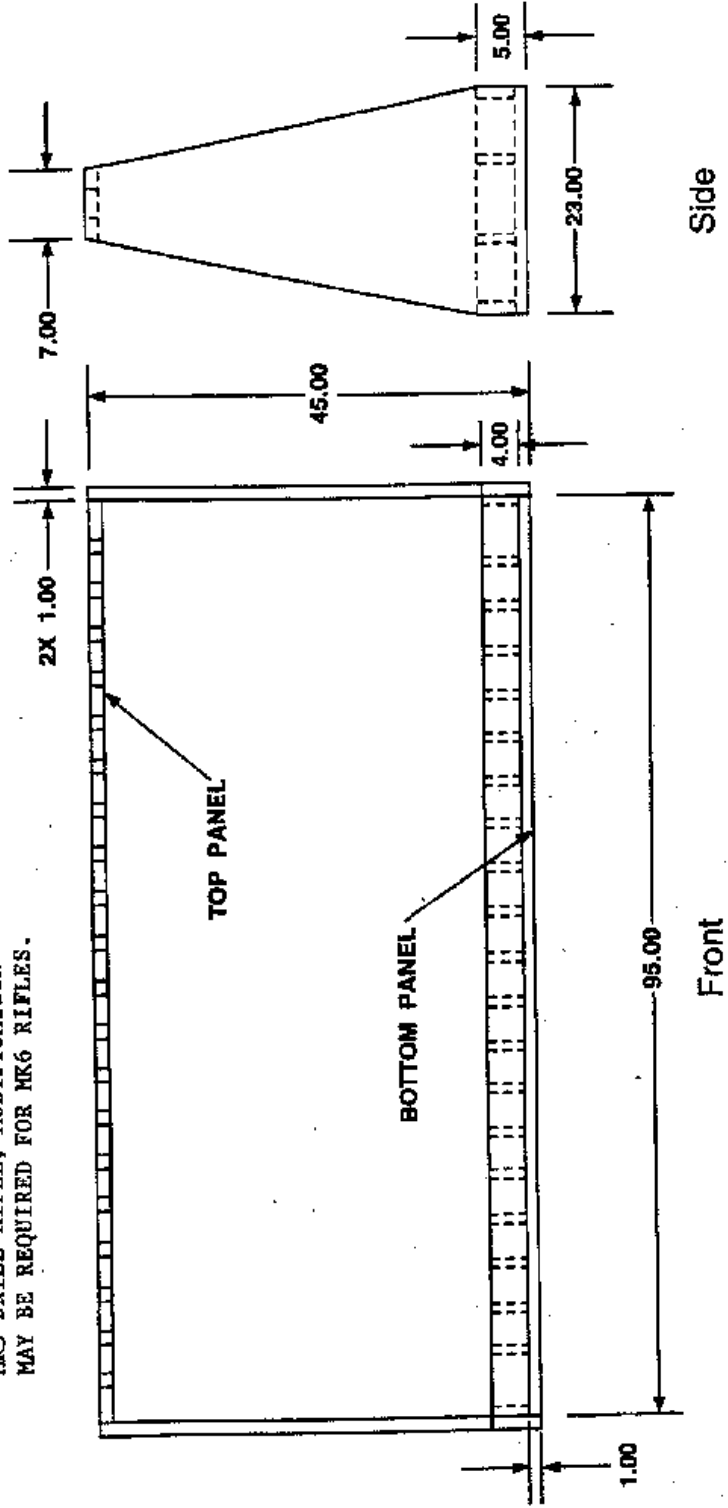

Figure 7-4. Wall Style Drill Rifle Storage Rack (Cont'd)

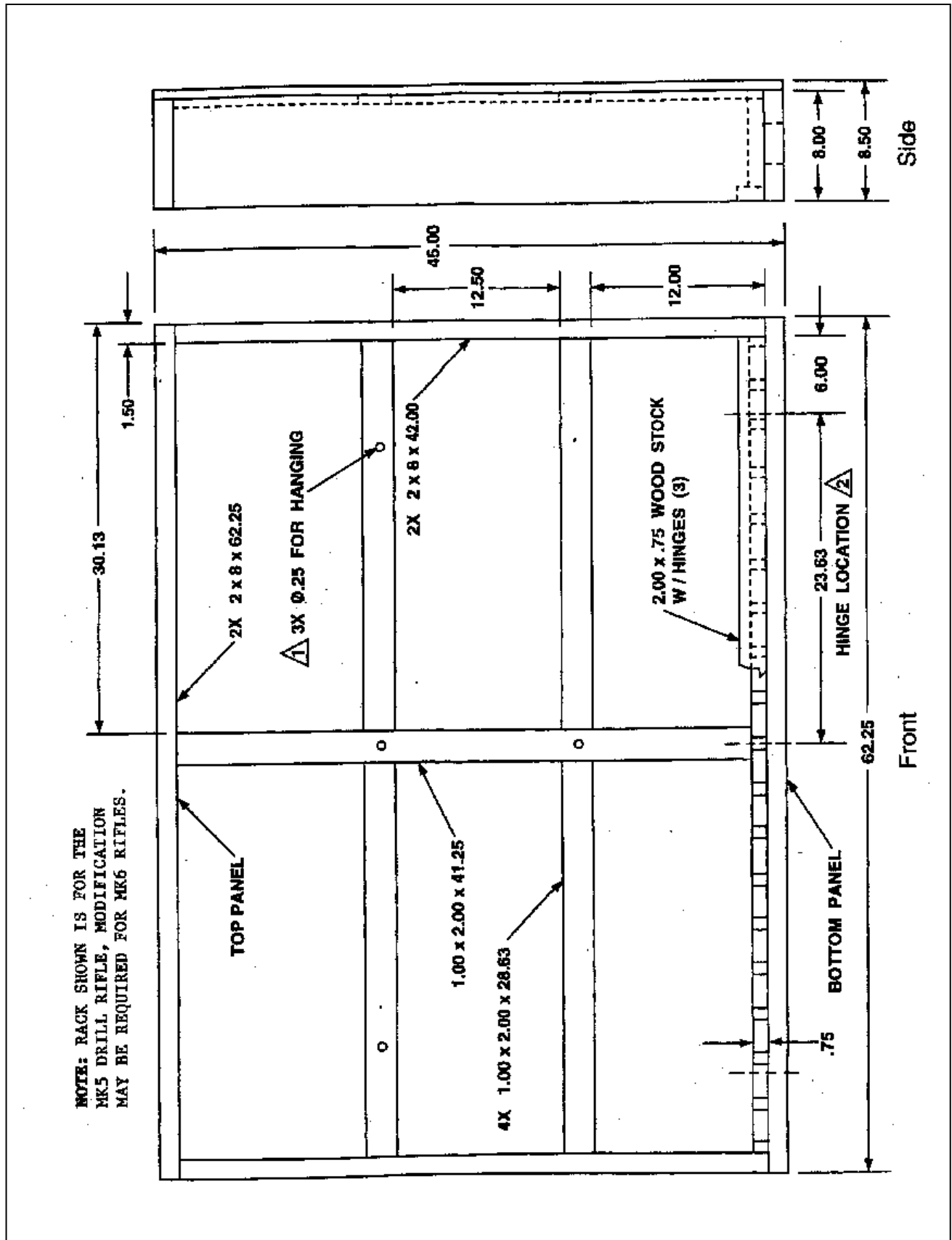

Figure 7-4. Wall Style Drill Rifle Storage Rack (Cont'd)

**Materials List**

- 4 - 2" x 8" x 8'
- 1 - 1" x 2" x 8'
- 3 - 1" x 2" x 8'
- 19 - .75" x 75" x 6.50"
- 1 - .5" x 62.25" x 45.00" PLYWOOD
- 3 - HINGES
- 30 - Ø.125 x 1.50LG" WOOD SCREWS
- 10 - Ø.125 x 2.25LG" WOOD SCREWS

**Notes**

1. HOLES FOR MOUNTING ON WALL CAN BE LOCATED AND DRILLED WHEN HANGING ON WALL.
2. HINGES TO BE CENTERED AND MOUNTED AS SHOWN BELOW
3. RIFLE RACK TO BE PAINTED OR VARNISHED BEFORE MOUNTING ON WALL.

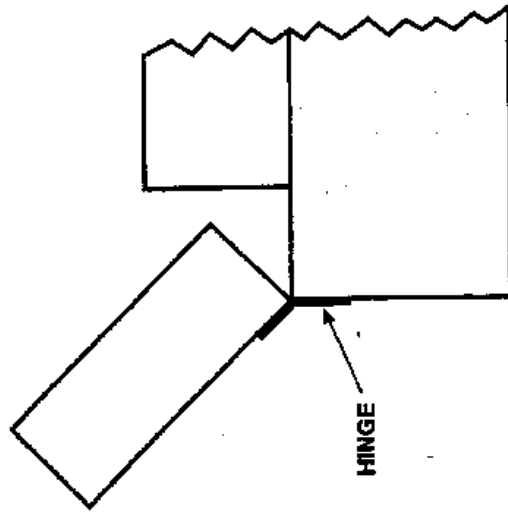

Figure 7-5. Free Standing Drill Rifle Storage Rack

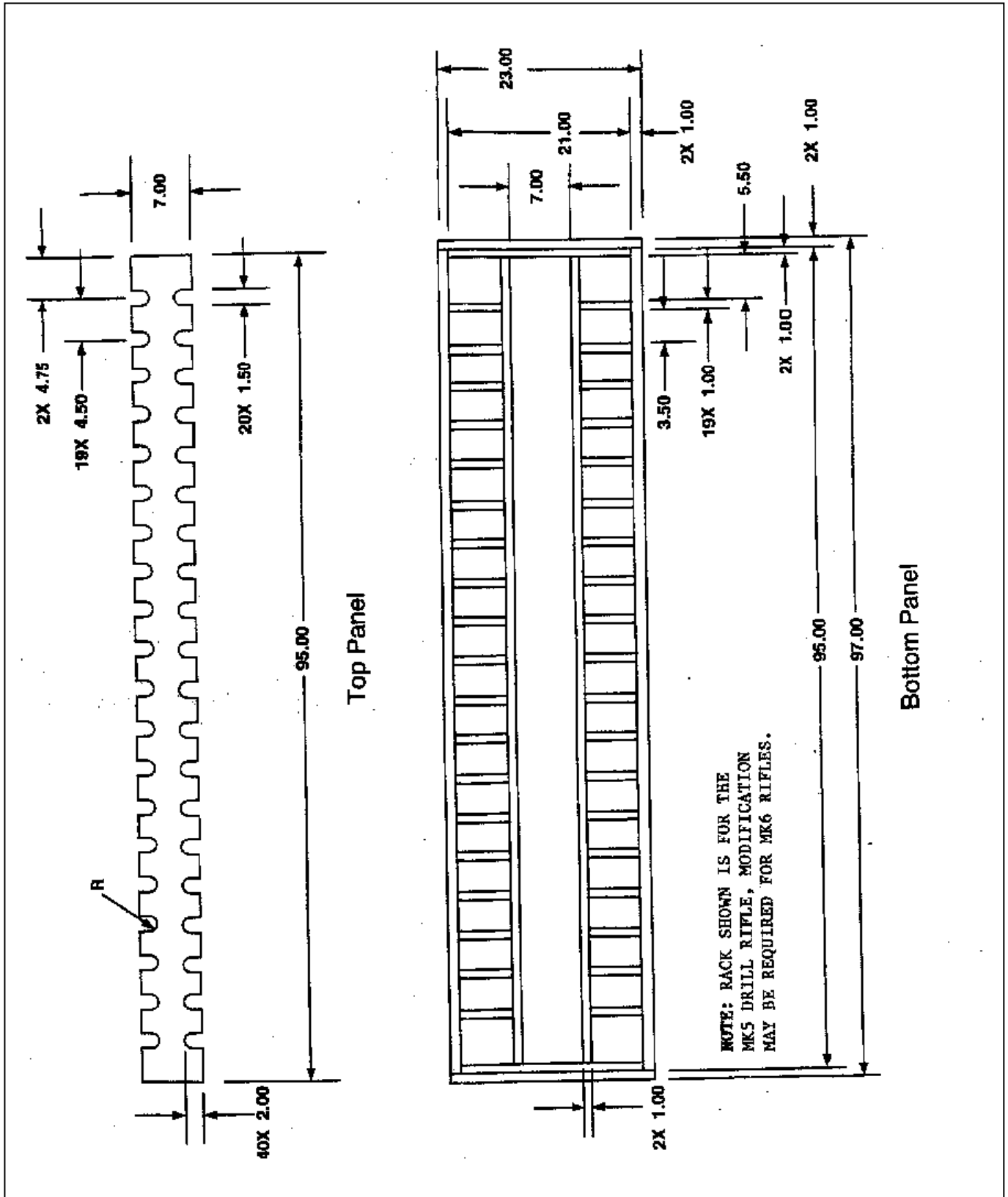
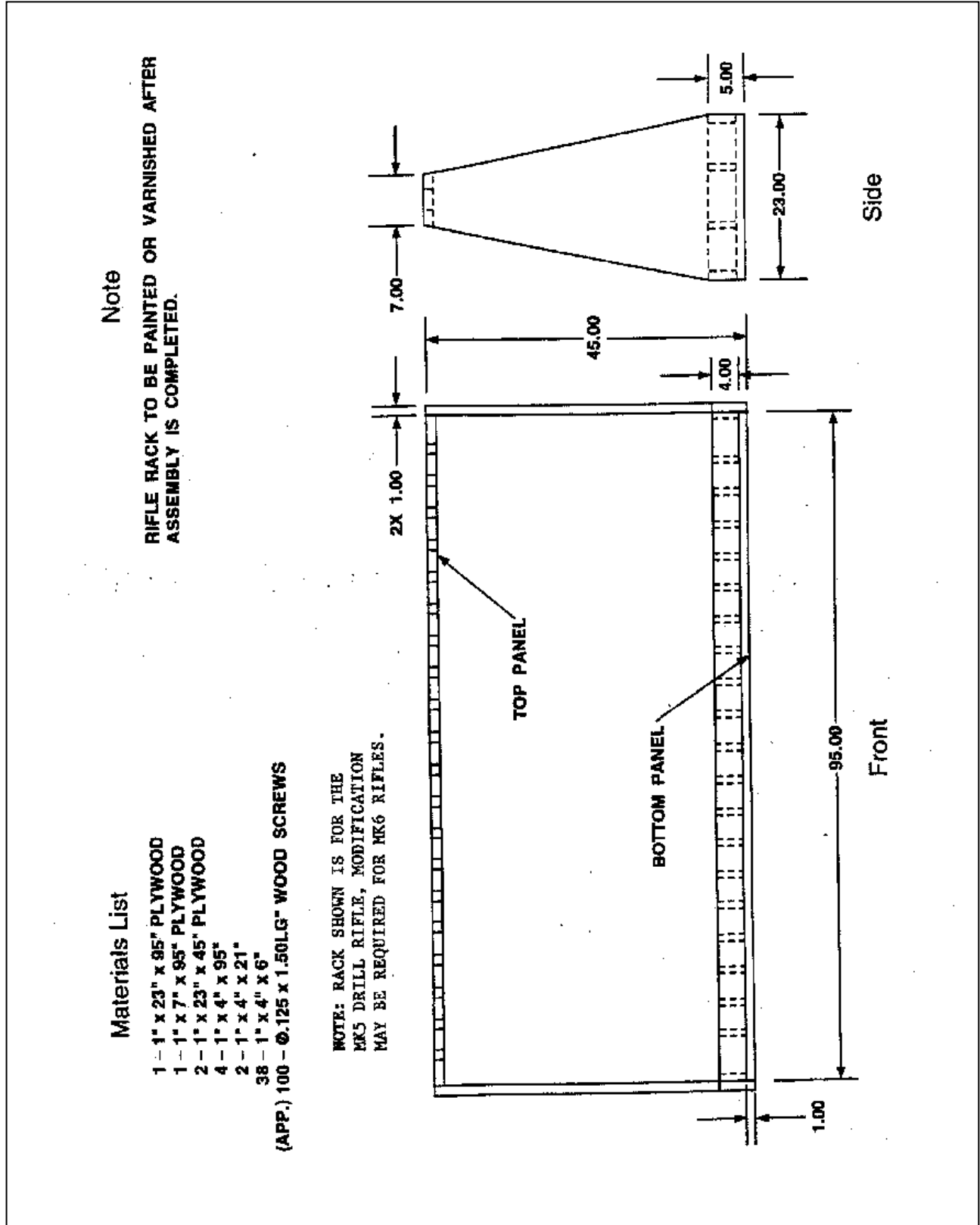

Figure 7-5. Free Standing Drill Rifle Storage Rack (Cont'd)







## CHAPTER 8: AIR RIFLES

### CLASSES

There are two (2) classes of air rifle competition: Sporter and Precision. Sporter is the beginner/intermediate level and Precision is the advanced/expert level. Each class requires different types of air rifles. **Precision air rifles will not be purchased by NSTC for NJROTC units. Purchase, repair, and maintenance of precision air rifles are the responsibility of the unit.**

### TYPES

There are several Sporter models of air rifles in use by the NJROTC program. The following are pneumatic air rifles authorized for use: Daisy 753, 853, 853C, and 953 (the 953 model has been phased out). The following are CO2 operated air rifles authorized for use: Crosman M2000 and Daisy M888. Parts diagram are shown in this chapter [are for the Daisy 953](#).

### AUTHORIZATION

NJROTC units are authorized ten (10) air rifles per unit if approved by a school official. Approval must be written on school letterhead and kept on file at the unit. Naval Science Instructors are encouraged to conduct small arms marksmanship and safety training. Air rifles (.177 caliber and lower) are the only small arms authorized for marksmanship training in the NJROTC program. **Units are specifically not authorized to have any operable rifles greater than .177 caliber.**

### ORDERING

[Units must submit requests to the Area Manager for approval and submission. Each Area Manager will submit a prioritized list of unit air rifle requirements by 15 July each year.](#) If funds are available, NSTC will issue a "Letter of Authorization" via NJROTC Official Mail (email). The unit will purchase air rifles with school funds per guidance, and submit a Standard Form 1034 for reimbursement.

### AMMUNITION

Instructors are authorized to locally procure air rifle pellets or BBs (.177 caliber or lower). The use of maintenance funds is authorized for this purchase.

### REPAIR

The NJROTC unit SNSI will be responsible for the safe operation of all air rifles. **Under no circumstances will the Navy-procured air rifles be modified.** The SNSI and staff members will review the manufacturer's manual and become knowledgeable of the air rifle's operation, disassembly, assembly, cleaning, repair, and safe handling requirements. Replacement parts for the air rifle will be obtained through the manufacturer or an authorized dealer. **The cost of repair parts is the responsibility of the unit.** The use of Unit Support and Maintenance funds is authorized for these purchases. Obtain current pricing information by calling 1-800-643-3458 for Daisy air rifles and 1-718-273-0666 for Crosman air rifles. There is no NSTC supply support for air rifle parts. Figure 8-1 is provided on an information only basis for the unit's convenience when ordering from Daisy.

## **INVENTORY**

Air rifle accountability is maintained as military property in the JUMS Supply Module.

## **SECURITY**

NJROTC air rifles will not be removed from school property except for use at an NJROTC event or with written permission of the SNSI or designated representative.

Air rifles require the same stringent storage as drill rifles. Storage must be stringent enough to preclude loss by theft or pilferage. At the minimum, the air rifle must be stored in a lockable container or storage rack in an area of limited accessibility, such as the unit equipment/clothing storeroom.

Figure 8-1. Repair Parts for Daisy 853

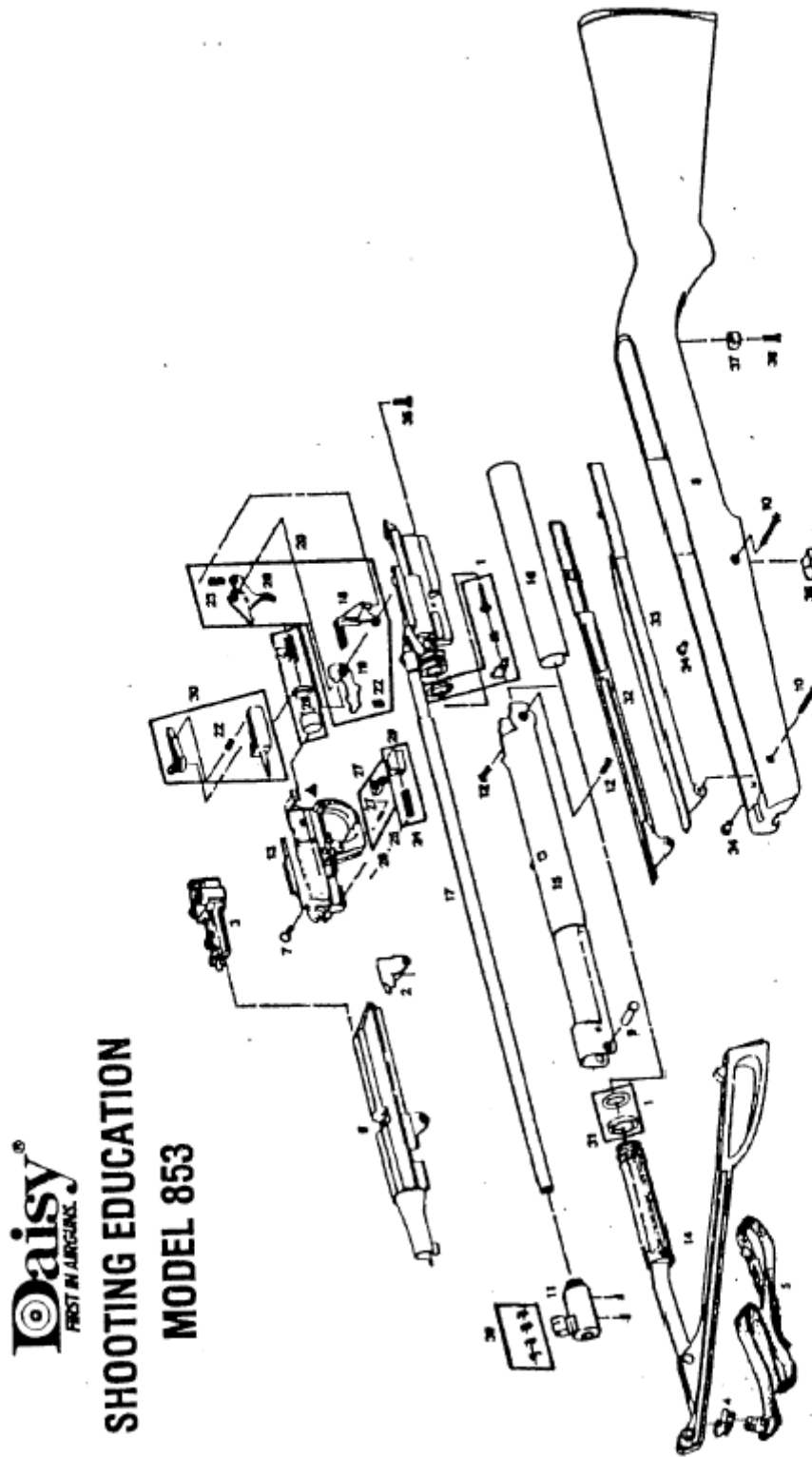

Figure 8-1. Repair Parts for Daisy 853 (Cont'd)

Key	Part number	Description
1	853-1	"O" ring & valve group (includes 31)
2	853-2	Band, barrel
3	5899	Sight, rear, adjustable peep
4	853-4	Bracket, sling
5	853-5	Sling assembly
6	853-6	Receiver 853
7	853-7	Screw assortment (includes 7, 9, 10, 12, 34, 35, 36, 37, 38)
8	853-8	Stock
9	853-9	Pin lever (included in 7)
10	853-10	Screw, stock (included in 7)
11	853-11	Sight, front
12	853-12	Screw, valve body (included in 7)
13	853-13	Housing, trigger
14	853-14	Pump lever assembly
15	853-15	Frame
16	853-16	Tube pump
17	853-17	Valve body and barrel assembly
18	853-18	Lock, trigger (included in 20)
19	853-19	Sear (included in 20)
20	853-20	Trigger assembly (includes 18, 19, 20, 22, 23)
21	853-21	Spring, hammer (included in 28)
22	853-22	Spring, bolt & sear (included in 20 & 30)
23	853-23	Spring, trigger (included in 20)
24	853-24	Spring, latch (included in 29)
25	853-25	Spring, safety (included in 27)
26	853-26	Ball safety (included in 27)
27	840-SY	Safety assembly (includes 25, 26)
28	853-28	Hammer (includes 21)
29	853-29	Latch, lever (includes 24)
30	853-30	Bolt, handle assembly (includes 22)
31	853-31	Wiper, pump & "o" ring (included in 1)
32	853-32	Filter, inletting, right
33	853-33	Filter, inletting, left
34	853-34	Nut, stock (2 ea included in 7)
35	853-35	Screw, valve body (included in 7)
36	853-36	Spacer, (included in 7)
37	853-37	Nut, stock block (included in 7)
38	853-38	Screw, sear (included in 7)
39	99Z	Sight inserts (4 ea)

## CHAPTER 9: PROPERTY MANAGEMENT

### INVENTORY CONTROL

An inventory is a physical count of items for the purpose of verifying the recorded stock balance. The unit has complete accountability for all government material provided for the unit. The inventory should be complete and accurate in order to provide a good audit track of all receipts, issues, and transfers.

The unit accounts for clothing, textbooks, and equipment on JUMS generated custody cards (chapters 2 and 3). Materials received from DOD or a commercial vendor usually arrive with a shipping document or invoice detailing the shipment. Military Property Custodians (MPCs) should ensure that the material and the quantity received matches the paperwork that accompanies the shipment. Report any variance to NSTC (NJROTC Supply) via the Area Manager Office as described in chapter 2.

### MILITARY PROPERTY CUSTODIAN (MPC)

The MPC is an SNSI or NSI or, [under extenuating circumstances \(i.e. SNSI and NSI depart without replace onboard, etc.\)](#), other school official appointed in writing by the school's principal. A copy of the appointment is required to be maintained on file at all times. A complete inventory of all naval property is required prior to the reappointment of the MPC position.

### NJROTC MILITARY PROPERTY

The term "military property" is defined as personal property acquired for immediate use and having a unit cost of \$5,000.00 but less than \$100,000.00. All furniture, fixtures, or office equipment costing more than \$5,000.00, all classified or sensitive equipment regardless of cost, and all pilferable equipment costing \$100.00 or more belonging to the Navy will be monitored through the property management system. NJROTC units will attach identification tags, commonly called "tool tags", to the equipment in order to comply with this requirement and will inventory this equipment as part of the annual Military Property Inventory. Tool tags are available from each Area Office.

**Property Identification** - All military property will be physically marked with an appropriate designation showing U.S. Navy ownership and a property control number (tool tag) provided by the Area Manager. The MPC will accomplish this by affixing each piece of military property (except drill rifles) with a tag, plate, or other device provided by the Area Manager containing the property control number. Drill rifles are not required to be tagged. A dummy tag number will be designated for all drill rifles to satisfy the mandatory tag number field in the JUMS program. The serial number of the drill rifles will be used to identify and track the items. The SNSIs will request identification tags for all items (except drill rifles) that fall within the definition of military property by providing the nomenclature, brand, model number, serial number, and price by letter to the Area Manager.

## ANNUAL INVENTORY

NJROTC units are required by NSTC to conduct an annual physical inventory to account for all government property that is listed as an allowance item by the unit. This inventory is generated in JUMS and is submitted to NSTC (NJROTC Supply) via the Area Manager Office each fiscal year, usually 15 April.

**Annual Inventory Instructions** - The annual inventory will be JUMS generated and physically verified by the SNSI. The military property inventory will be verified and signed by the Area Manager and submitted as part of the Area Manager's On-Site Inspection Report each time an on-site inspection is conducted.

## RELIEF FROM RESPONSIBILITY

The unit must have an MPC assigned at all times. If the MPC leaves prior to the hiring of a replacement, the SNSI must appoint another MPC. The SNSI, NSI, or some other school official will be appointed as the MPC. The MPC will be designated in writing by the SNSI or, in the SNSI's absence, a school official. The MPC designation letter will be forwarded to the Area Manager. The following paragraphs describe the actions required when there is a change in MPC.

**Joint Inventory** – the relinquishing and relieving MPC will accomplish an inventory. The discrepancies, shortages, and overages will be adjusted by the relinquishing MPC using JUMS survey procedures prior to transfer of property responsibility. The results of this inventory will be reported on a certificate of transfer letter. A sample letter is shown below.

### NJROTC UNIT LETTERHEAD

Date

From:

To:

Subj: PROPERTY TRANSFER CERTIFICATE

I,           name of receiving MPC          , certify that the balance shown on the property records maintained within NJROTC unit   UIC   as of   date   are correct to the best of my knowledge and that the property is in my custody.

I,           name of relinquishing MPC          , certify that the balance shown on the property records maintained within NJROTC unit   UIC   as of   date   are correct and that I am relieved of the responsibility for all unit property.

---

Signature of receiving MPC

---

Signature of relinquishing MPC

**Property Transfer** - A copy of the certification of transfer letter will be provided to the Area Manager and the relinquishing MPC, and a copy will be retained by the relieving MPC in the document file.

## **CUSTODY TRANSFER**

**General** - The Area Manager must approve the transfer of all NJROTC unit property. This includes all items on loan to other NJROTC units. **All transfers must be accomplished via JUMS with a JUMS generated Property Record.** These files should be reviewed prior to any required inventory.

A transfer between NJROTC units is normally called a no-cost transfer. The material is already part of the NSTC Inventory Management Program. **If shipping is required** a DD-1149, Requisition and Invoice/Shipping Document will be prepared by NSTC (NJROTC Supply) upon request.

## **EXCESS PERSONAL PROPERTY**

**IT Equipment** - Upon determination and concurrence by the Area Manager that an item is in excess of unit allowance or obsolete, disposition instructions must be obtained from NSTC (NJROTC Supply). The disposal (turn in) of government material to the Defense Reutilization and Marketing Office (DRMO) is required to be documented on a DD-1348-1A, DOD Single Line Item Release/Receipt Document. The DD-1348-1A will be prepared and forwarded to the unit upon request from NSTC (NJROTC Supply). **Units without ready access to DRMO facilities may donate excess IT equipment to schools, churches, or other non-profit organizations. As a last resort local disposal is authorized. Computer hard drives must be wiped to DOD standards or rendered inoperative prior to donation or disposal.**

## **SURVEY**

**General** - The JUMS generated survey report (DD-200), Financial Liability Investigation of Property Loss, is used to document the survey process when government property is lost, damaged, destroyed, or becomes obsolete. This form is the official document to support establishment of debts, relief from accountability, and adjustment of accountable records. Since all material and property is accountable through JUMS, all surveys will be generated using JUMS.

## **MISSING, LOST, STOLEN, OR RECOVERED GOVERNMENT PROPERTY**

Formal reporting of missing, lost, stolen or recovered government property except for high-risk arms, ammunition, and explosives, and classified material has been eliminated. No material or property held by a NJROTC unit falls into the exception category. However, the Area Manager and appropriate local civil authorities should be notified expeditiously if the following are missing, stolen or recovered.

- All firearms or weapons, regardless of value (NJROTC drill rifles are included for reporting purposes).
- All serialized government property having a value of \$100.00 or more.
- All government property considered “sensitive items” regardless of the actual or estimated value.
- All un-serialized government property having a value of \$500.00 or more.
- A single incident resulting in a cumulative loss of serialized or un-serialized government property exceeding \$500.00.





# CHAPTER 10: DONATIONS OF SURPLUS PERSONAL PROPERTY

## GENERAL INFORMATION

Surplus government property may be available for NJROTC use. Donations may be made only as authorized with respect to the disposal of surplus property of the armed services and defense agencies. In addition, the Secretary of a military department may donate, without expense to the United States, certain material not needed by the DOD. The donation of surplus property to an authorized unit is subordinate to any need for property by a federal agency, but takes precedence over its sale, destruction, or abandonment.

## SCREENING CATEGORY

NJROTC units are authorized to screen and accept donations from a Defense Reutilization Marketing Office (DRMO). Under new guidance from Defense Logistic Agency (DLA), NJROTC units are now categorized as donation-screening activities. Donation screeners are limited to set times, dates and property availability. Likewise, depending upon the location, donation screeners may be charged a fee for property selected. NSTC (NJROTC) does not fund fees levied by DRMO.

## SCREENING LETTER

A screening letter must be prepared to authorize personnel to screen and select surplus DOD property at DRMOs in a given GSA region. A sample letter is shown below:

*Figure 10-1. Screening Letter*

NJROTC UNIT LETTERHEAD			
Reference:	Defense Reutilization and Marketing Service (DRMS) letter dated		
Subject:	Identification of Donation Screener(s)		
1.	In accordance with the referenced letter, the following individual(s) is(are) authorized to screen and select surplus DOD property at Defense Reutilization and Marketing Offices in GSA Region(s) ___ :		
Screeener Name	Region, Unit	Mailing Address	Phone
2.	Screening privileges may be terminated upon evidence of unauthorized use or abuse of such privileges.		
3.	Copies of this letter have been provided to the applicable GSA region(s) identified in paragraph (1) of this letter.		
Your Signature	_____		

## **ITEMS DONATABLE TO NJROTC UNITS**

The types of personal property authorized for donation to NJROTC units are limited to those items required to fill shortages in the unit's authorized allowance or such items as clothing, office supplies, shelving, etc.

## **APPLICATION FOR DONATION OF SURPLUS PROPERTY**

An application for donation of surplus property is processed using forms and procedures established by DRMO. The Area Manager must approve all requests for surplus property and forward DRMO screening forms to NSTC (NJROTC Supply) who will produce and provide to the unit the appropriate documentation for surplus property pickup.

## **CHAPTER 11: PROCEDURES FOR DISESTABLISHMENT**

### **GENERAL**

When it becomes necessary to disestablish a NJROTC unit such disestablishment will be directed by SECNAV. If disestablishment is at the option of the Navy, it will normally occur at the end of the current academic year and be completed no later than 30 June.

### **ACCOUNTABILITY**

Unless otherwise authorized by NSTC, all Navy provided materials, including textbooks, references, training aids, uniforms, naval artifacts, Navy-owned equipment, drill and air rifles (and related ammunition), and organizational equipment in the custody of the unit being disestablished will revert to Navy custody by 30 June. To properly account for the inventory, turnover, and shipment of these materials, the Area Manager will establish a mutually satisfactory schedule with the Military Property Custodian assigned by the host school in accordance with the written agreement. The host school officials should be advised that the Navy share of reimbursement for instructors will continue through the 30 June date to reassure them, and the Area Manager, that knowledgeable personnel will be available for assistance.

### **DISPOSITION GUIDANCE PLAN**

- 1. Inventory** - Account for all Navy-owned property by producing a current JUMS Military Property, and a Clothing Wall-to-Wall Inventory. Compare this inventory data to that of the last annual Military Property and Clothing Wall-to-Wall Inventory Report to NSTC, and perform a sight verification of on-hand property. Reconcile any differences to the Area Manager's satisfaction. Document all gains and losses via a JUMS generated survey.
- 2. Turnover and receipt for assets.**
- 3. Shipment and/or storage of Navy-owned materials**

### **DISPOSITION OF MATERIALS**

Actual disposition of Navy-owned property and material will vary by unit location. The Area Manager will coordinate with NSTC (NJROTC Supply) to redistribute these assets to other NJROTC units, or for return to NSTC. NJROTC Supply will prepare and provide to the Area Manager all necessary documentation for transfer and/or shipment.

### **DISPOSITION OF FUNDS COLLECTED**

Funds collected as reimbursement to the Navy for lost books and/or uniforms shall be in the form of a money order or certified check made payable to "Treasurer of the United States" and shall be accompanied by a JUMS generated survey for said items. Funds should be mailed to the Area Manager Office who will then forward funds to NSTC (NJROTC Supply).

## **DISPOSITION OF ADMINISTRATIVE MATERIAL**

Student records, PAO and local history records shall be sent to the Area Manager to be retained for seven years. Local disposition is recommended for the curricula, lesson plans, NJROTC instructions, directives, regulations, etc. If there is an abundance of office supplies, refer to the Area Manager for disposition instructions.

## **PACKING AND SHIPPING MATERIALS**

NSTC (NJROTC Supply) will provide guidance and shipping documentation to the Area Manager concerning shipping and packing materials and shipping method. When a military base with shipping facilities is within reasonable proximity, NSTC (NJROTC Supply) will liaison with the shipping facility to arrange packing and shipping. In remote locations where no military base with shipping facilities is available, NSTC (NJROTC Supply) will provide guidance concerning alternatives.